

Assembly, installation and maintenance manual

Montage-, Aufbau- und Wartungsanleitung • Assemblage, manuel de montage et d'entretien • Montaje, instalación y mantenimiento • Manuale di montaggio, installazione e manutenzione • Monterings- og vedlikeholdsmanual • Monterings-, installations- och underhållsmanual • Kokoamis-, asennus- ja huolto-ohje • Vejledning for montering og vedligehold • Handleiding voor montage, installatie en onderhoud • Manual de montagem, instalação e manutenção • Návod k montáži, instalaci a údržbě • Instrukcja montażu, instalacji i konserwacji • Surinkimo, montavimo ir priežiūros vadovas • Montāžas, uzstādīšanas un apkopes rokasgrāmata • Руководство по сборке и обслуживанию • Montaaži-, paigaldus- ja säilitamise juhend



Element house **EL18-4633-2**

<p>Factory inspection by • Werkskontrolle durch • Contrôle à partir de l'usine par • Inspector de fábrica • Collaudato da • Fabrikkkontroll utført av • Fabriksbesiktigat av • Tehtaan tarkastaja • Fabriks Kontrol udført af • Fabriekscontrole door • Inspeção de fábrica, por: • Zkontrolováno ve výrobním závodě • Kontrola fabryczna do • Apžiūrą gamykloje atliko • Rūpnīcas pārbaudi veicis • Заводской контроль • Tehase kontroll teostatud:</p> <p>.....</p>	<p>Date • Datum • Date • Fecha • Data • Dato • Datum • Päiväys • Dato • Datum • Data • Datum • Data • Datums • Data • Дата • Kuupäev:</p>
	<p>Pack number • Pack Nr. • Packet n° • Bulto N° • Pacco N. • Serienr • Produktionsnummer • Pakettinro • Pakke nr. • Pak nr. • Número de embalagem • Číslo balení • Numer opakowania • Pakuotės numeris • Iepakojuma numurs • Упаковочный номер • Pakinumber:</p>



www.palmako.ee/information-hub

English: Before installing and using the product, please read the instructions and warranty terms at www.palmako.ee/information-hub to guarantee proper installation and long-lasting performance.

Deutsch: Wichtig! Bitte vor Aufbau und Nutzung des Produkts unbedingt die detaillierte Montageanleitung sowie die Garantiebedingungen unter www.palmako.ee/information-hub lesen, um eine fachgerechte Montage und eine lange Funktionssicherheit zu gewährleisten.

Français: Avant d'installer et d'utiliser le produit, veuillez lire les instructions et les conditions de garantie sur www.palmako.ee/information-hub afin de garantir une installation correcte et la longévité du produit.

Español: Antes de instalar y utilizar el producto, lea las instrucciones y las condiciones de garantía en www.palmako.ee/information-hub para asegurar una instalación correcta y una larga vida útil del producto.

Italiano: Prima di installare e utilizzare il prodotto, leggere le istruzioni e le condizioni di garanzia su www.palmako.ee/information-hub per garantire una corretta installazione e prestazioni durature.

Norsk: Før montering og bruk av produktet, vennligst les monteringsanvisningene og garantivilkårene på www.palmako.ee/information-hub for å sikre korrekt montering og fremtidig holdbarhet.

Svenska: Innan du installerar och använder produkten, vänligen läs instruktionerna och garantivillkoren på www.palmako.ee/information-hub för att säkerställa korrekt installation och produktens långvariga hållbarhet

Suomi: Ennen tuotteen asentamista ja käyttämistä, lue ohjeet ja takuehdot osoitteessa www.palmako.ee/information-hub varmistaaksesi oikean asennuksen ja pitkäkestoisen toiminnan.

Русский: Перед установкой и использованием изделия ознакомьтесь с инструкцией и условиями гарантии на сайте www.palmako.ee/information-hub, чтобы гарантировать правильную установку и долговечность изделия.

Eesti: Enne toote paigaldamist ja kasutuselevõttu lugege palun juhiseid ja garantiitingimusi aadressil www.palmako.ee/information-hub, et tagada nõuetekohane paigaldus ja toote pikk eluiga.

Dansk (Oversat af AI): Læs venligst instruktionerne og garantibetingelserne på www.palmako.ee/information-hub, før du installerer og bruger produktet, for at garantere korrekt installation og langvarig ydeevne.

Dutch (Vertaald door AI): Lees vóór de installatie en het gebruik van het product de instructies en garantievoorwaarden op www.palmako.ee/information-hub om een correcte installatie en langdurige werking te garanderen

Português (Traduzido por IA): Antes de instalar e utilizar o produto, leia as instruções e os termos de garantia em www.palmako.ee/information-hub para garantir uma instalação adequada e um desempenho duradouro.



Čeština (Přeloženo umělou inteligencí): Před instalací a použitím produktu si prosím přečtěte pokyny a záruční podmínky na www.palmako.ee/information-hub, abyste zaručili správnou instalaci a dlouhodobý výkon.





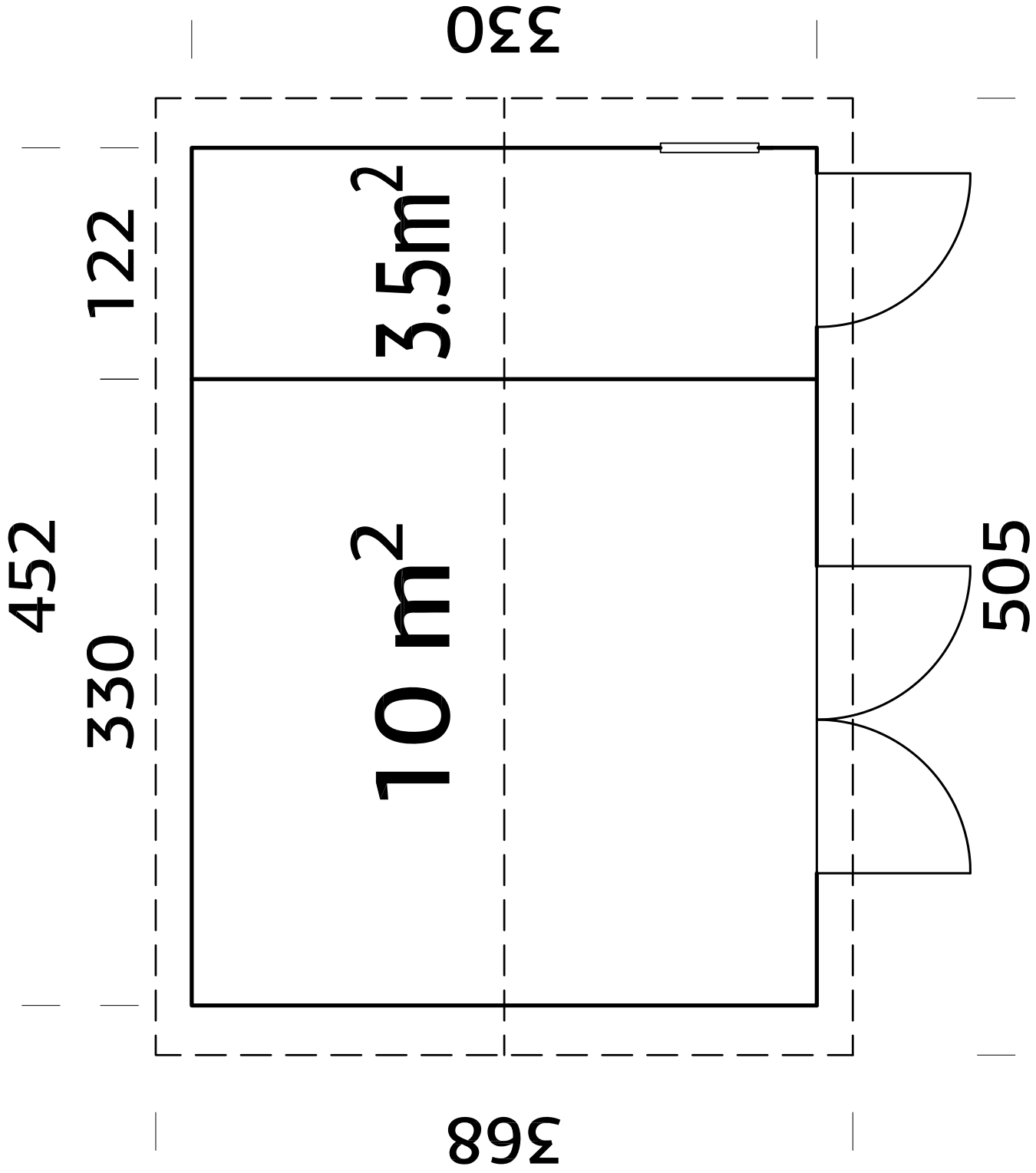

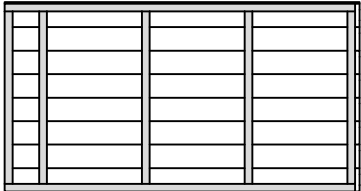
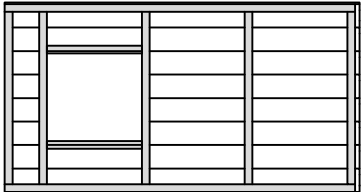
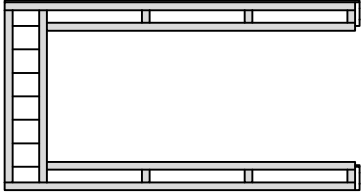
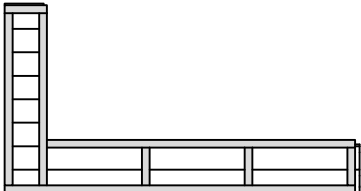
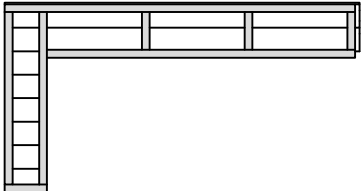
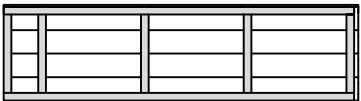

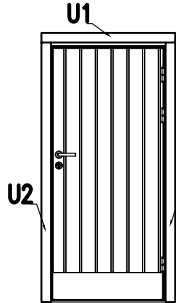
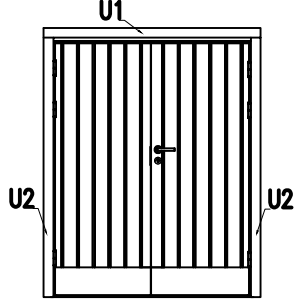
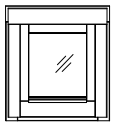













Polski (Przetłumaczone przez AI): Przed zainstalowaniem i użyciem produktu należy przeczytać instrukcję oraz warunki gwarancji dostępne na stronie www.palmako.ee/information-hub, co pozwoli zagwarantować prawidłową instalację i długotrwałą wydajność.

Latviešu (Mākslīgā intelekta tulkojums): Pirms produkta uzstādīšanas un lietošanas, lūdzu, izlasiet instrukcijas un garantijas noteikumus vietnē www.palmako.ee/information-hub, lai garantētu pareizu uzstādīšanu un ilgstošu darbību.

Lietuviškai (Išvertė DI): Prieš montuodami ir naudodami gaminį, perskaitykite instrukcijas ir garantijos sąlygas adresu www.palmako.ee/information-hub, kad užtikrintumėte tinkamą montavimą ir ilgalaikį veikimą.

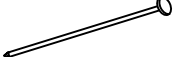

EL1		2055 x 1097 x 88	9
EL2		2055 x 1097 x 88	1
EL3		2055 x 1097 x 88	1
EL4		2055 x 1097 x 88	1
EL5		2055 x 1097 x 88	1
EL6		2055 x 553 x 88	2
EL7		3297 x 495 x 88	2
U90-20-919P	 <p>U1 - 19x70x980 2 pcs U2 - 19x70x1880 4 pcs</p>	870 x 1885 x 90	1
TU90-20-1519P	 <p>U1 - 19x70x1580 2 pcs U2 - 19x70x1880 4 pcs</p>	1470 x 1885 x 90	1
A50-5		500 x 540 x 50	1

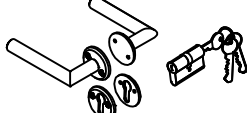
1		Treated	45 x 70 x 4488	2
2		Treated	45 x 70 x 3171	9
3			19 x 89 x 4488	37
4			44 x 120 x 4984	1
5			44 x 120 x 4384	4
6			44 x 120 x 212	8
7			28 x 120 x 4984	2
8			19 x 89 x 1880	112
9			16 x 95 x 5016	2
10			32 x 40 x 2492	4
11			16 x 120 x 2145	8
12			19 x 70 x 1945	4
13			18 x 135 x 2055	4
14			28 x 114 x 3121	21
15			45 x 45 x 2070	2
16			19 x 95 x 432	1
17			19 x 95 x 622	3
F1		QKRPP6x120Zn	Ø 6 x 120	18
F2		QKRPP4_5x70Zn	Ø 4.5 x 70	180
F3		QKRPP4x50Zn	Ø 4 x 50	270
F4		QKRPP2_5x16Zn	Ø 2.5 x 16	12
F5		QNA3x70Zn	Ø 3 x 70	800
F6		QKA100x150Zn	100 x 150	2
F7		QNU60x60x40Zn	60 x 60 x 40	8
F8		QLIUY QULSI35x35-1 QULKAY-1		2 sets

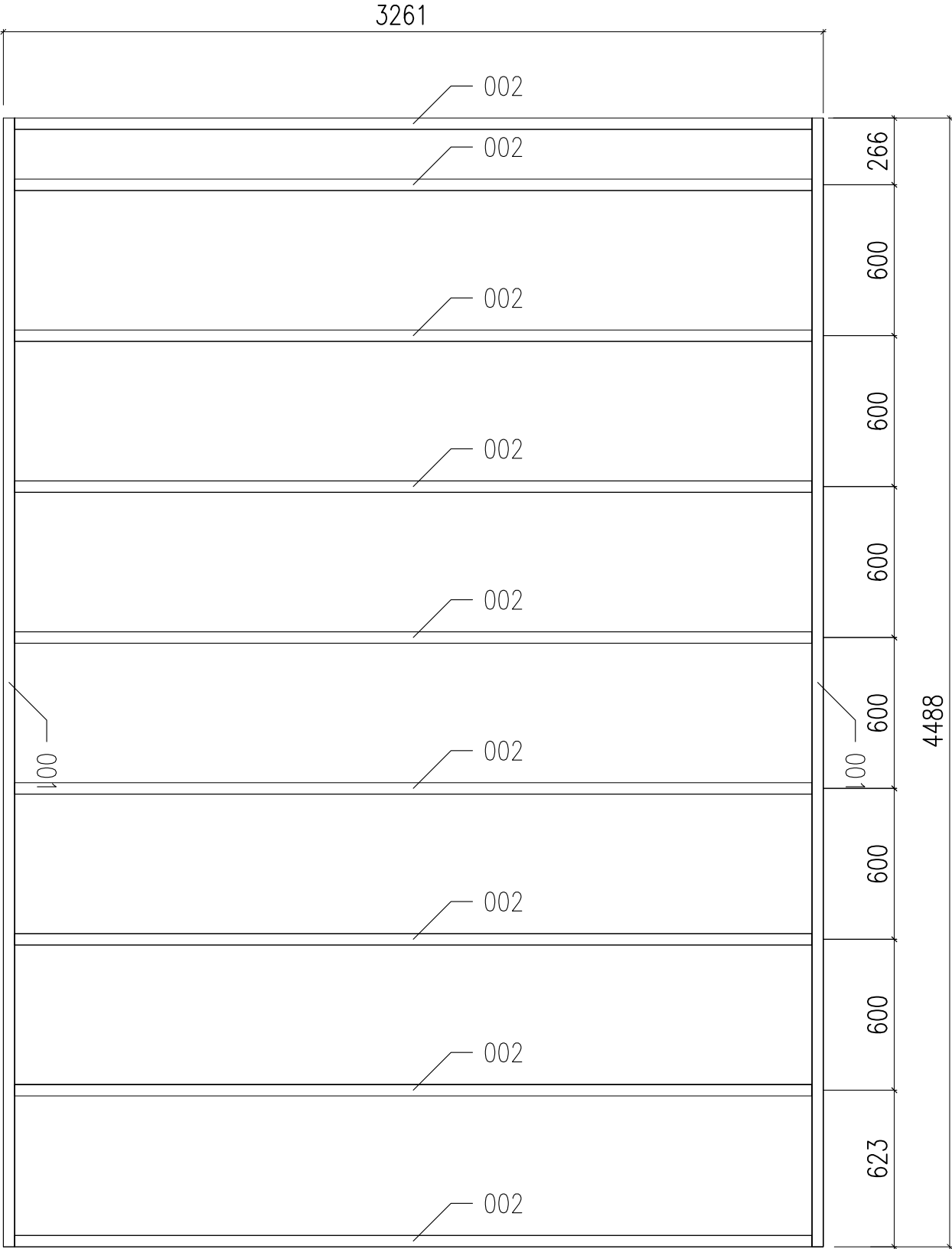

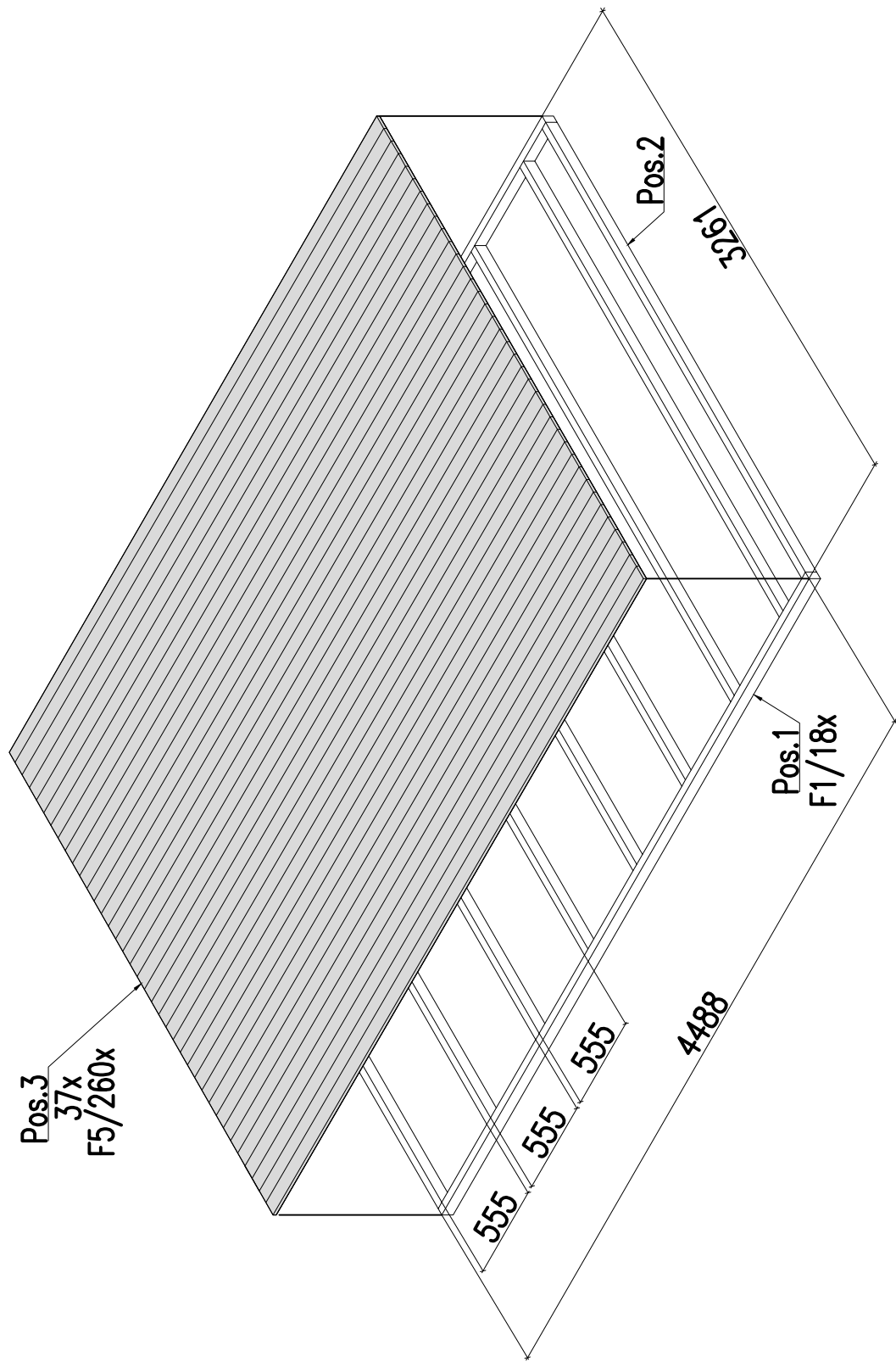

2

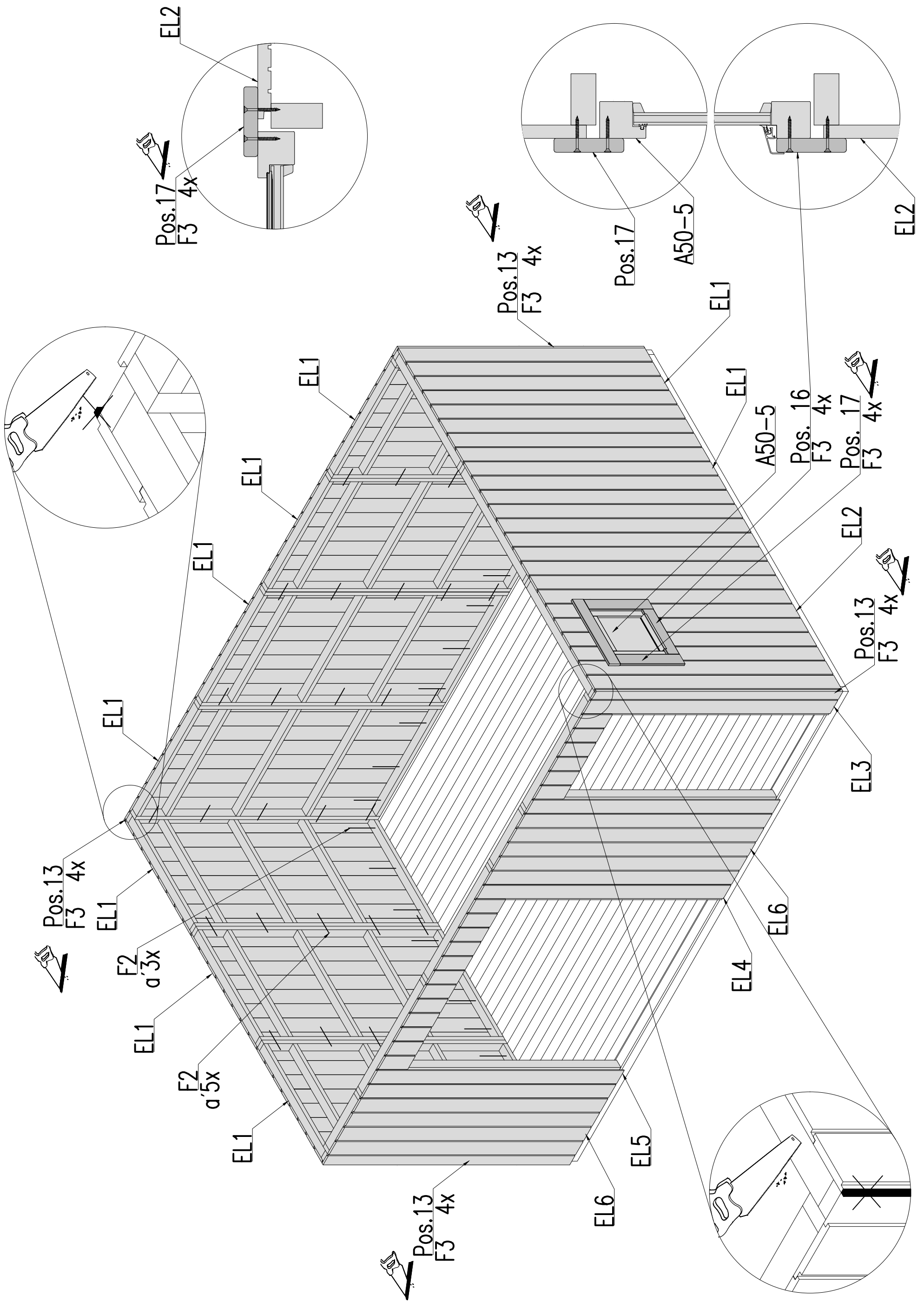

3

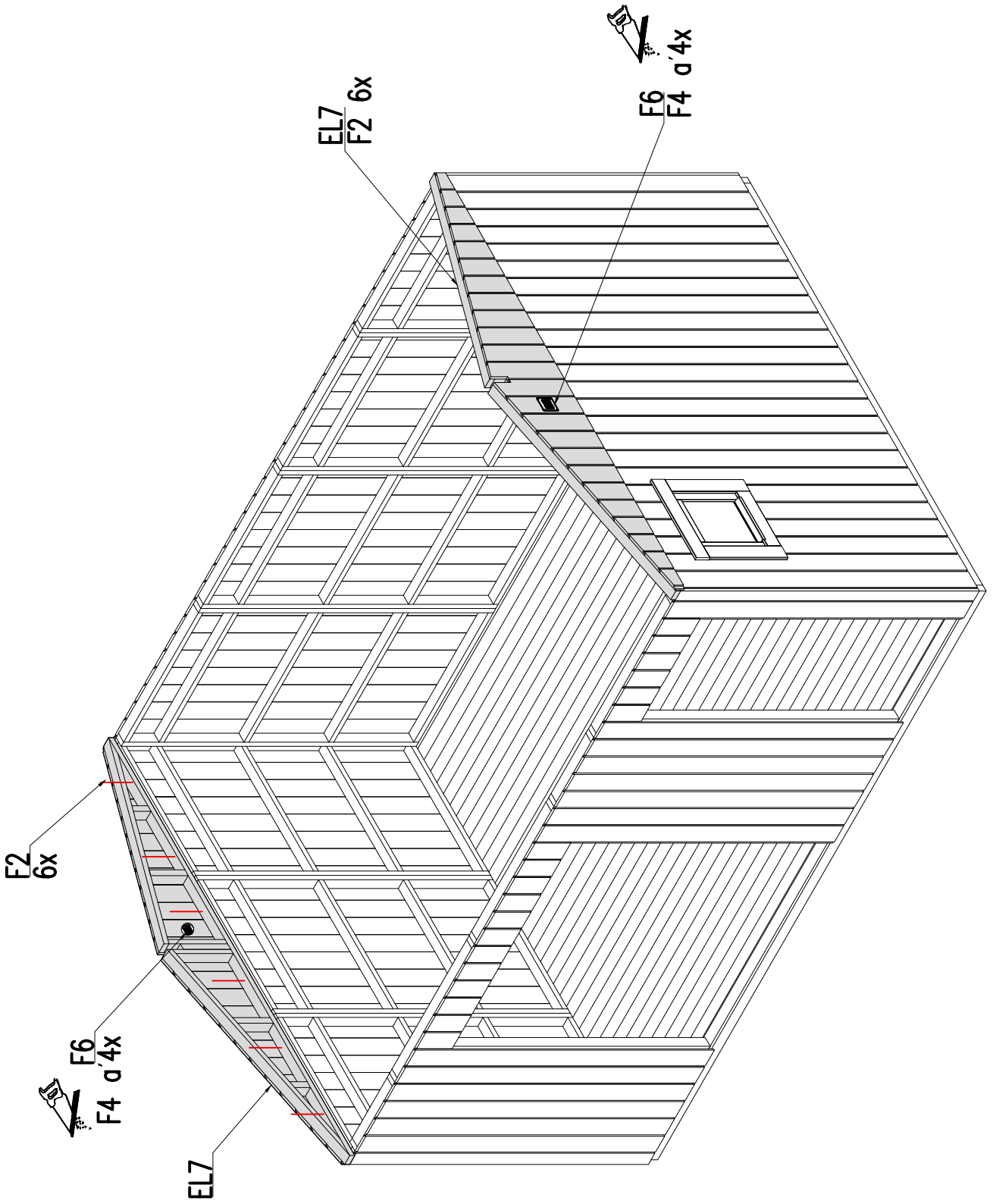

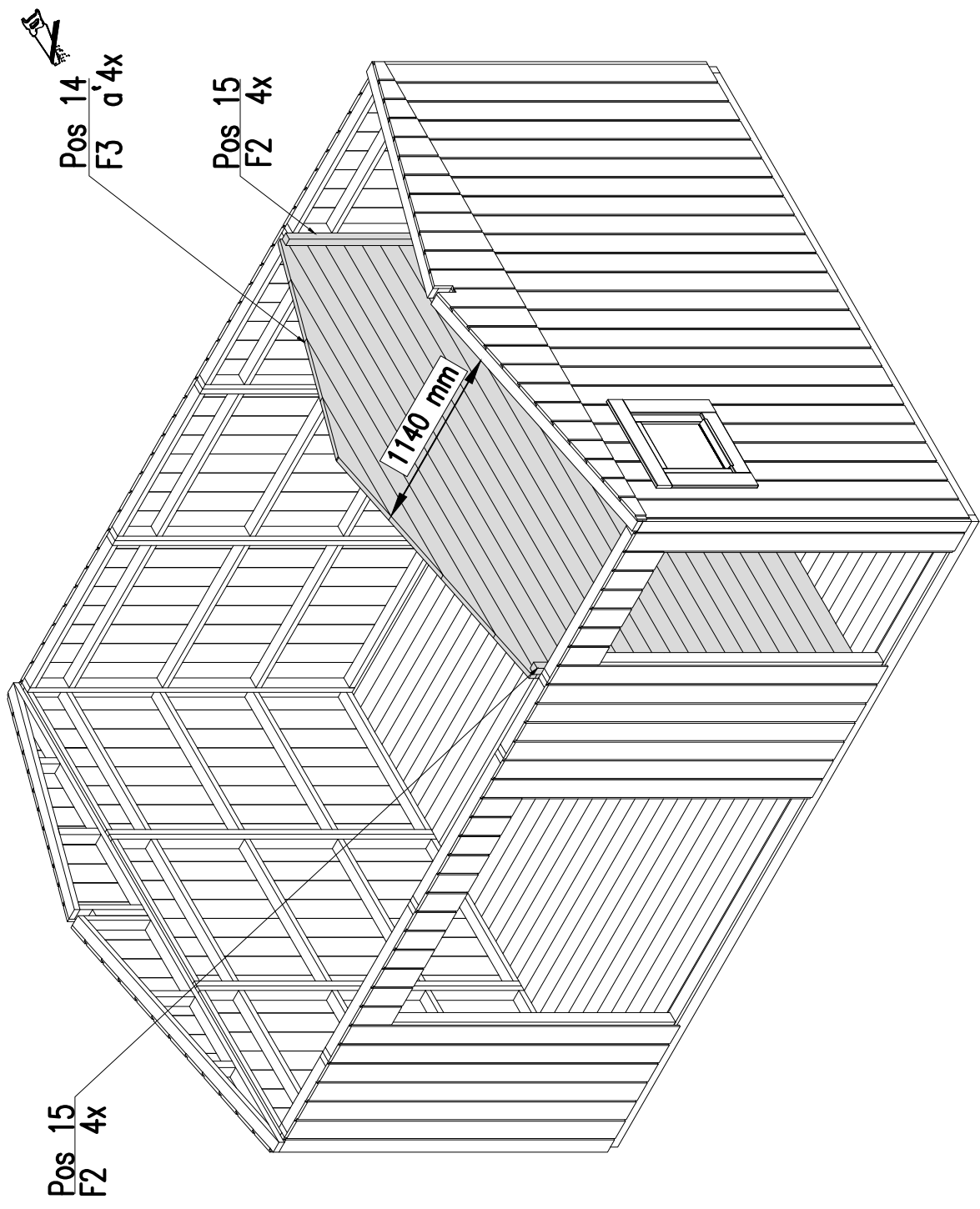

5

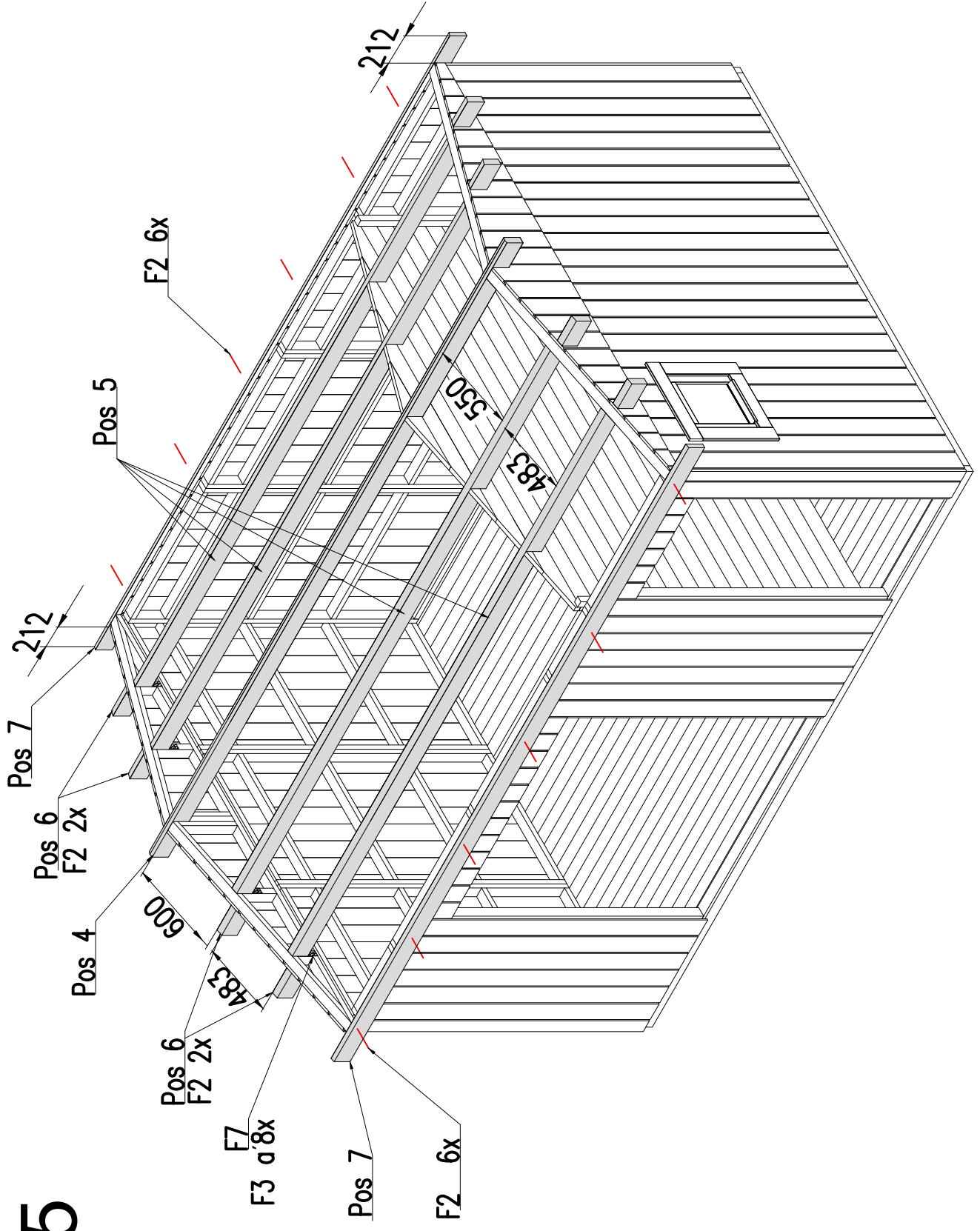

6

Pos.8 112x
F5 460x

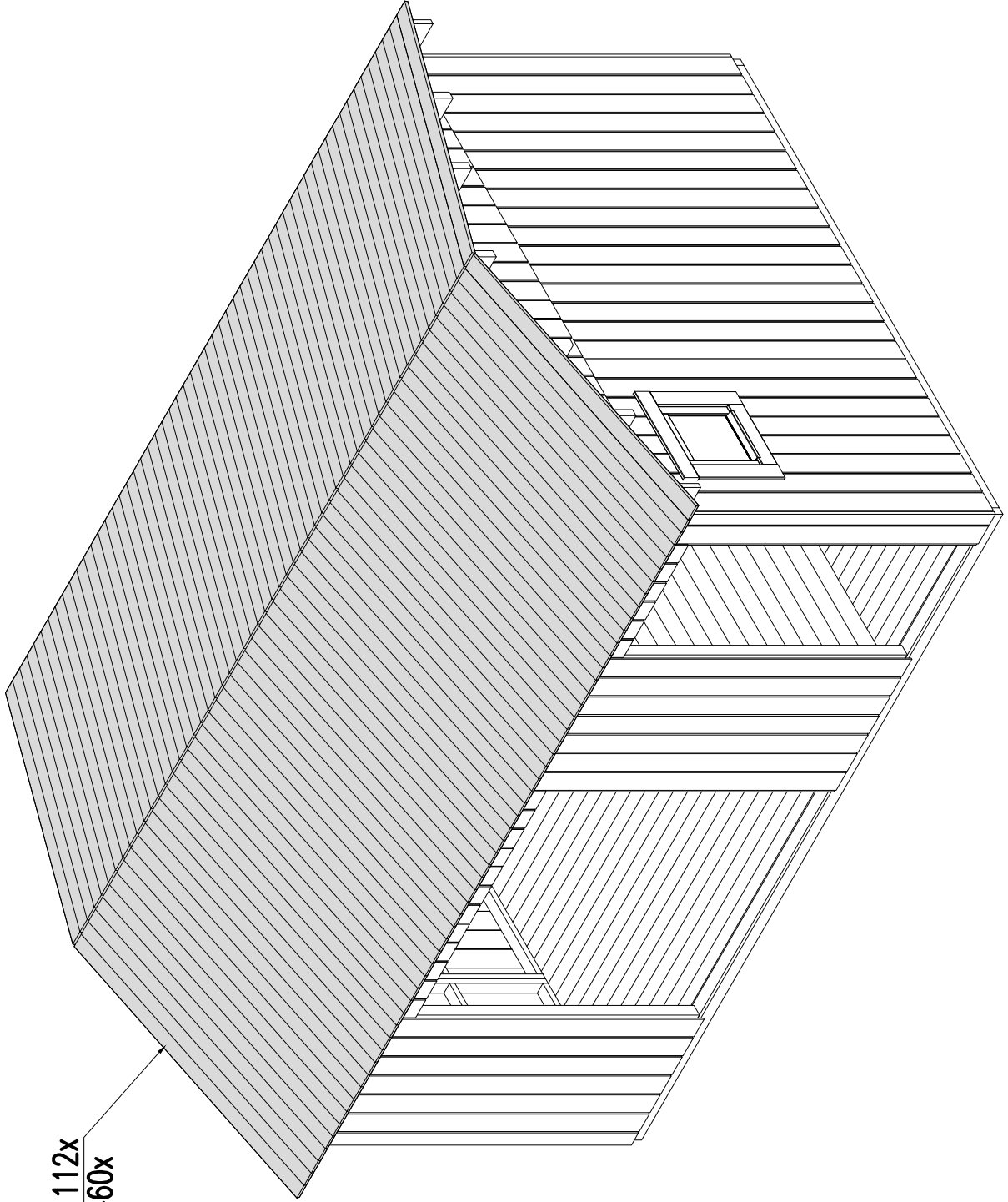

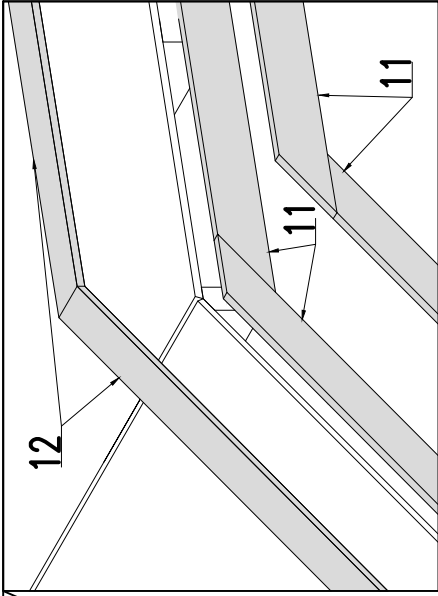
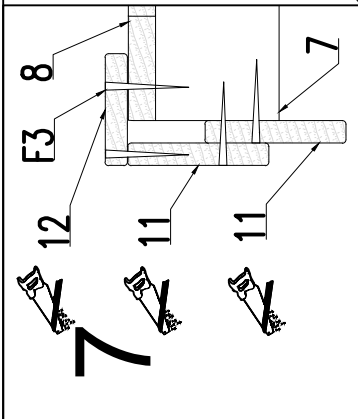

9
F3 α'8x
10
F3 α'5x

11
F3 α'6x

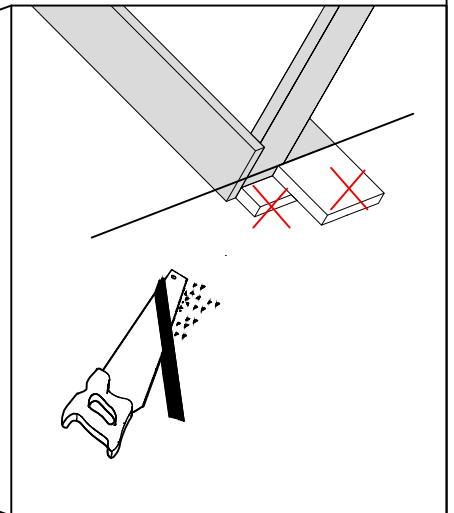
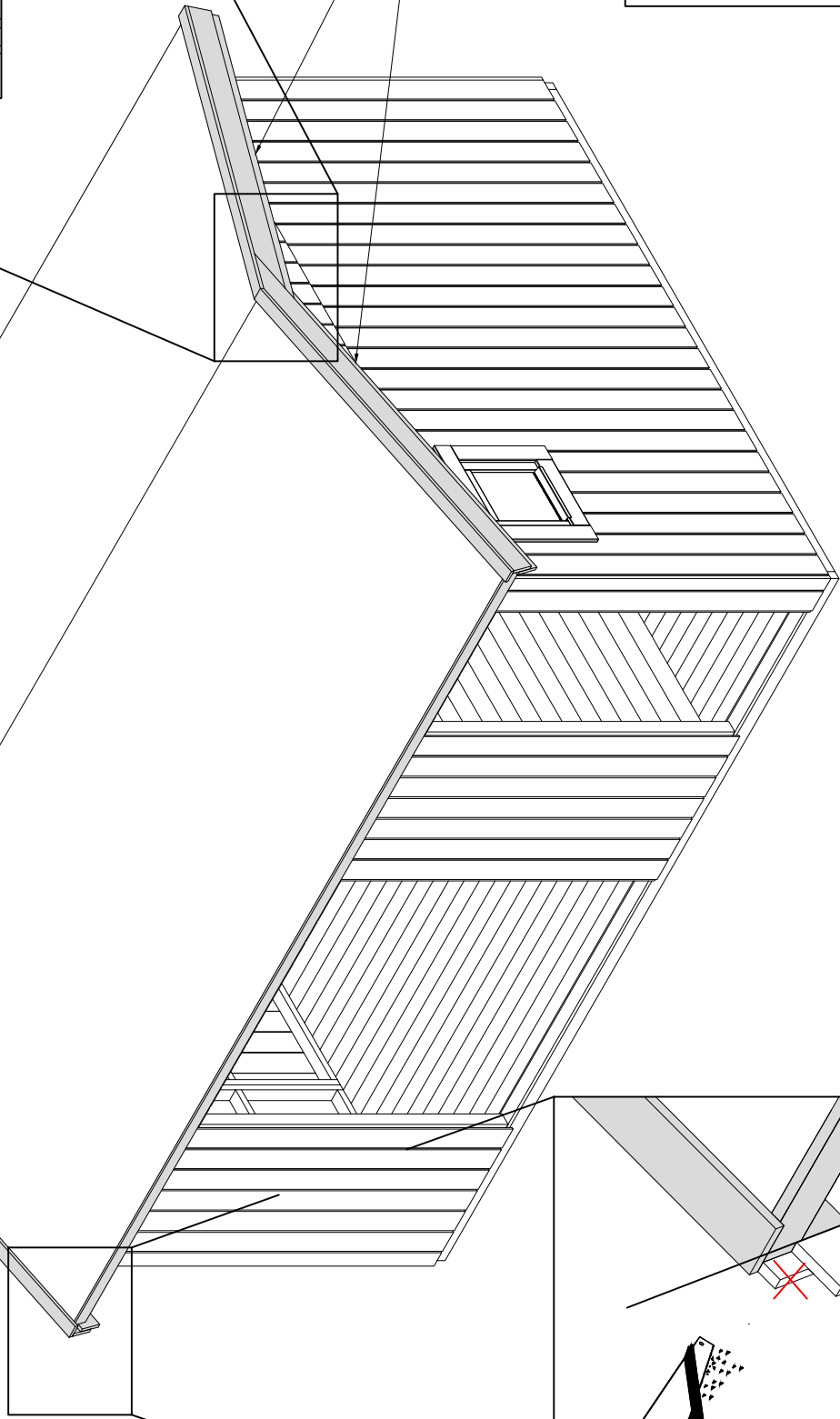
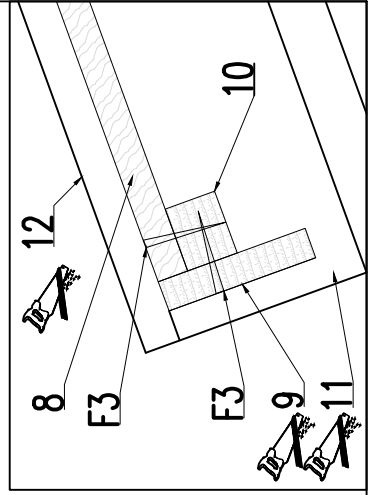

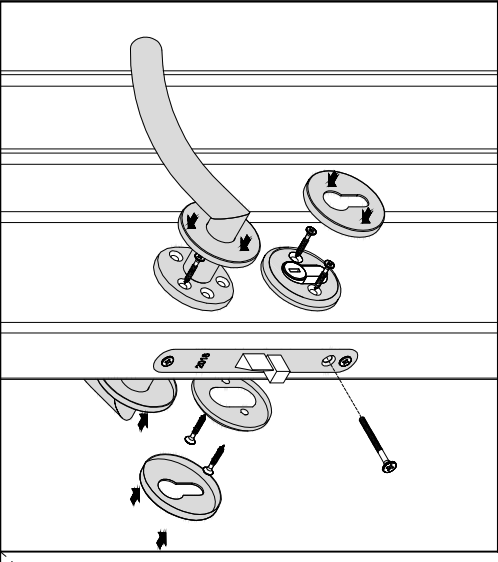
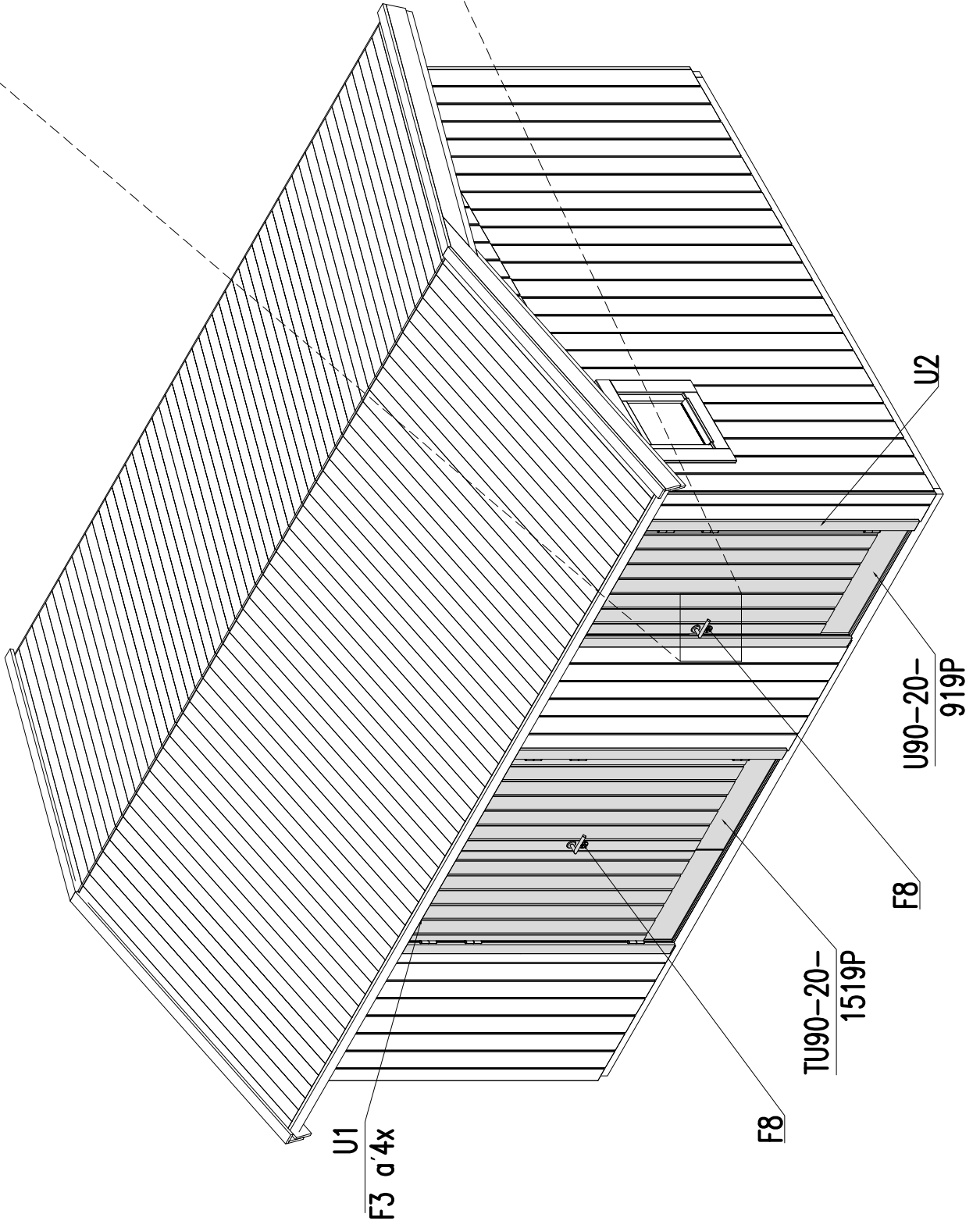

Installation instructions / Monteringsanvisning / Monteringsforskrift / Monteringsvejledning /
Asennusohjeet / Paigaldusjuhend

TU90-20-1519P

15x19



TU90-20-1519P
15x19

Palmako
LEMEKS GROUP

Palmako
LEMEKS GROUP

Näituse 25, 50409, Tartu, Estonia
Tel: +372 735 5530
Fax: +372 735 5544
www.palmako.ee

Note! Product that is used outdoors, needs to be painted before usage.

Notera! Produkt som används utomhus måste målas före användning.

Bemærk! Produkter, der anvendes udendørs, skal være malet før brug.

Merk! Produktet som skal brukes utendørs, må males før bruk.

Huomio! Ulkona käytettävät tuotteet täytyy värjätä ennen käyttöä.

Pane tähele! Kui toodet kasutatakse välitingimustes, tuleb seda enne kasutamist värvida.

Caps between window frame and door cladding needs to be filled with silicone before outdoors usage.

Håligheter mellan fönsterglaslist och träpanel behöver fyllas med fog innan utomhusanvändning.

Hulrum mellem vindue glas lister og paneler skal fyldes med fugemasse eller andet fyld før udendørs brug.

Hulrom mellom vindu glass listverk og trepanel må fylles med fugemasse eller annen fylling før utendørsbruk.

Välit ikkunankehysten ja oven laudoituksen välillä täytyy tasoittaa silikonilla ennen ulkokäyttöä.

Välitingimustes tuleb aknaraami ja ukse laudise vahel olevad vahed täita silikooniga.

TOOLS REQUIRED

VERKTYG SOM DU BEHÖVER

VERKTUJ, DU SKAL BRUGE

VERKTÜY SOM DU TRENGER

ASENNUKSESSA TARVITTAVAT TYÖKALUT

VAJALIKUD TÖÖRIISTAD

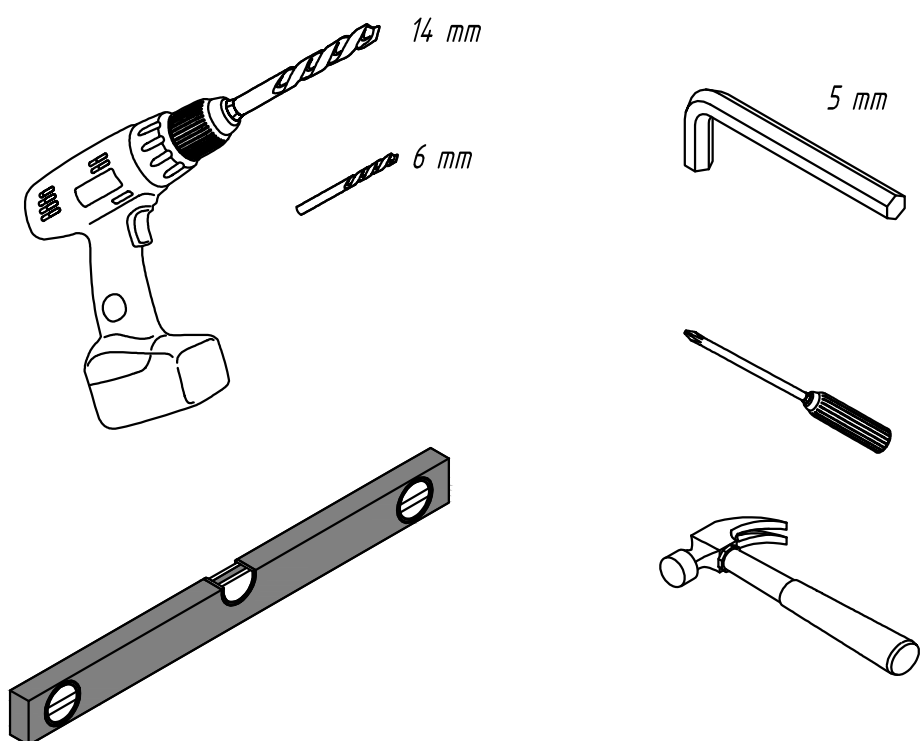

ACCESSORIES NOT INCLUDED

TILLBEHÖR SOM DU BEHÖVER

TILBEHØR, DER IKKE MEDFØLGER

TILBEHØR SOM IKKE FØLGER MED

ASENNUKSESSA TARVITTAVAT TARVIKKEET

PUUDUVAD LISAMATERJALID

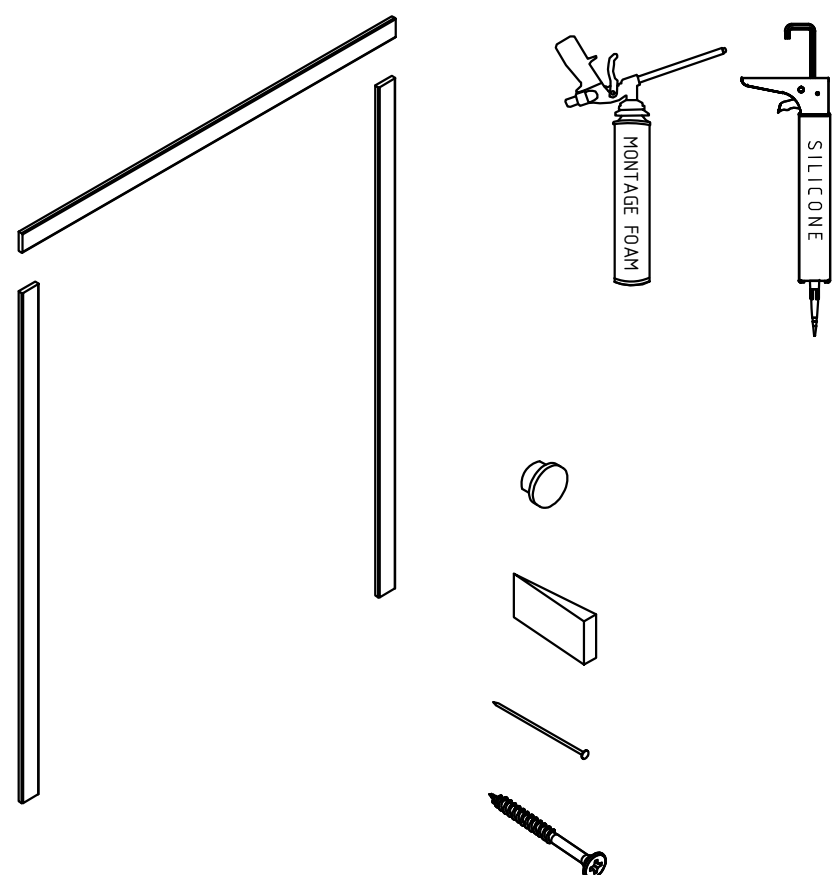

1

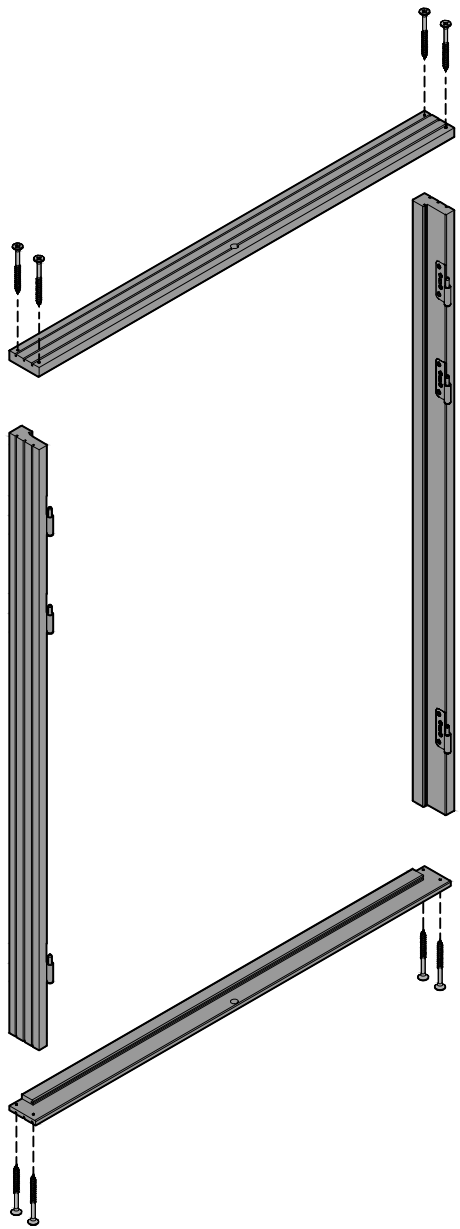

3

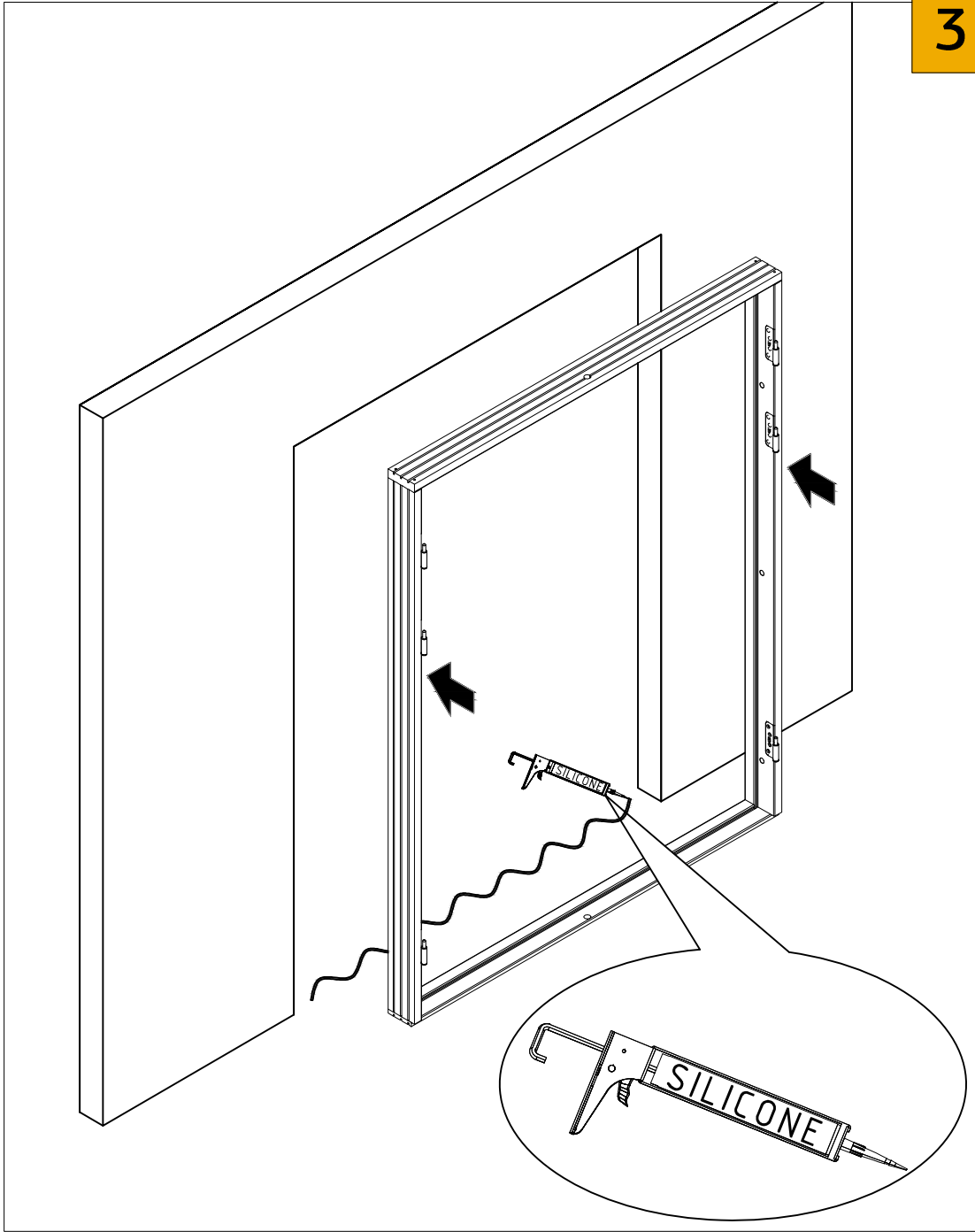

2

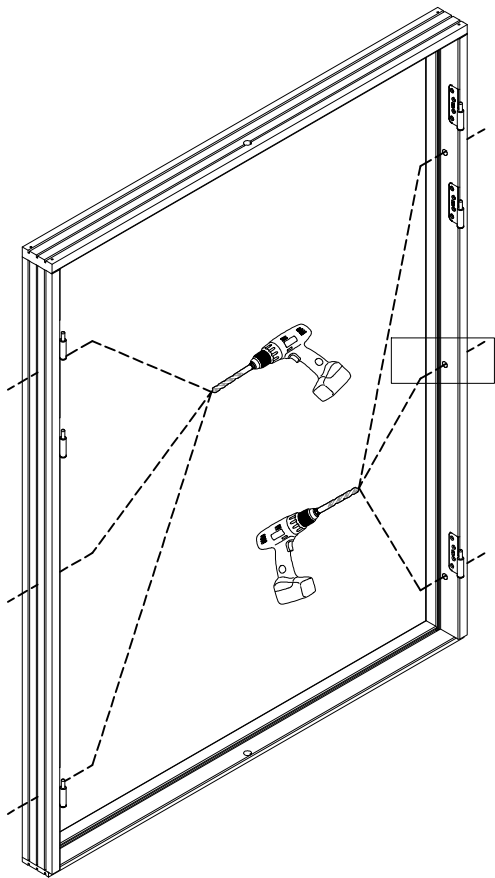

4

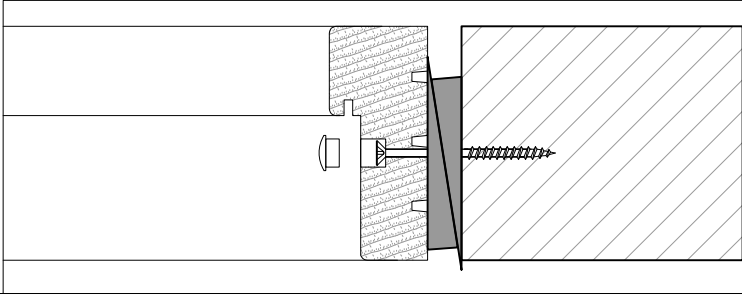
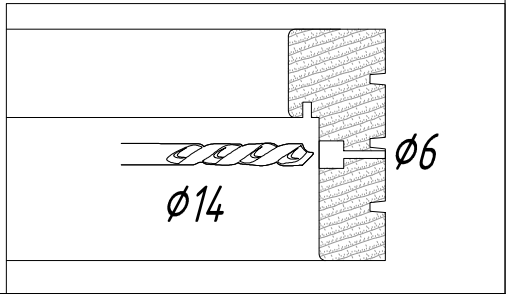
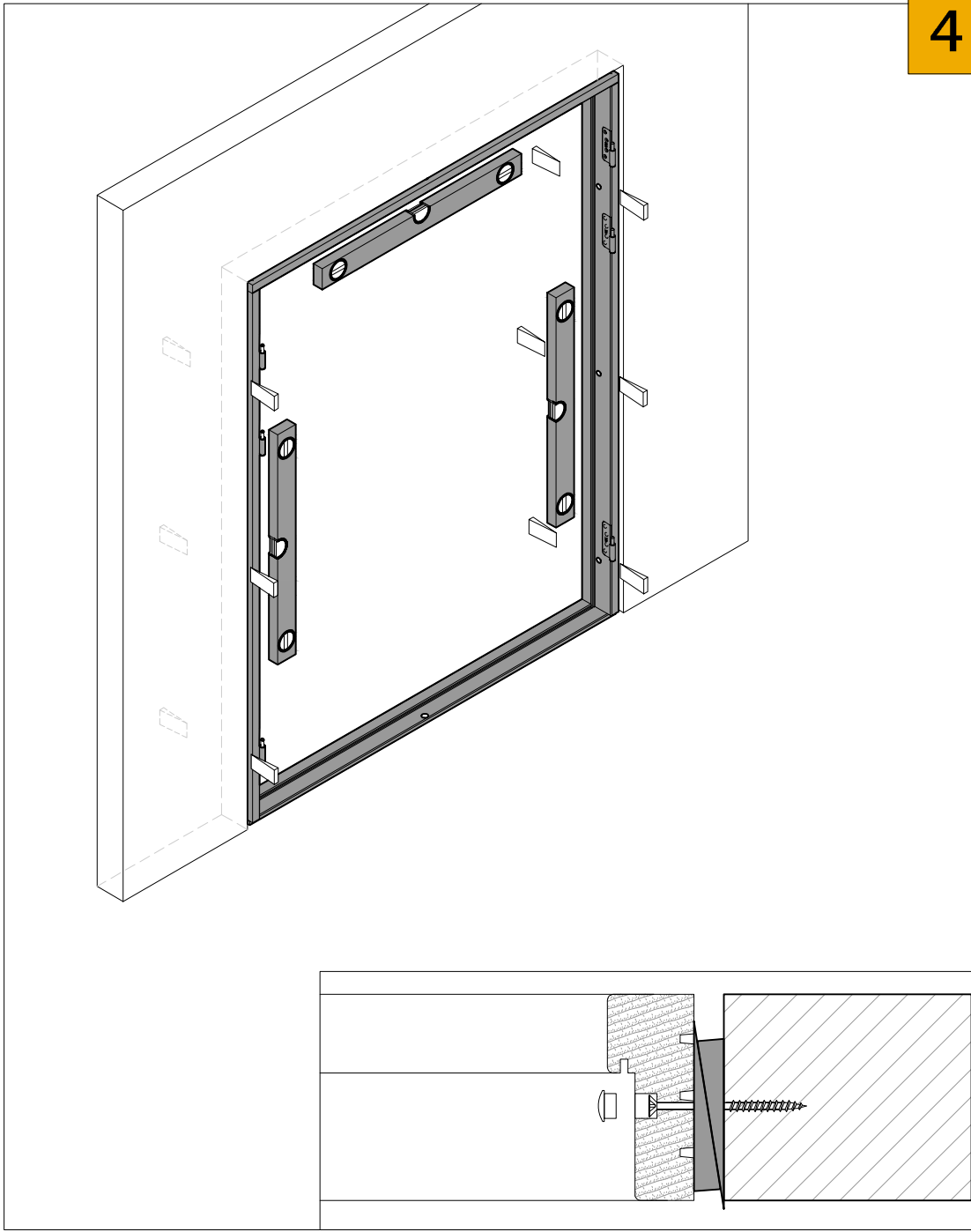

5

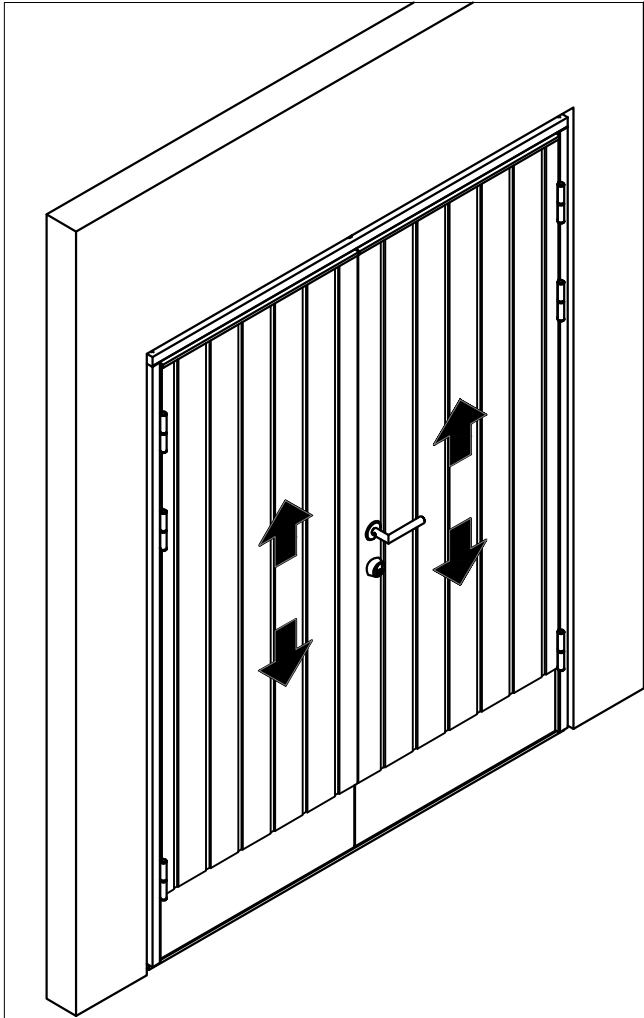

5a

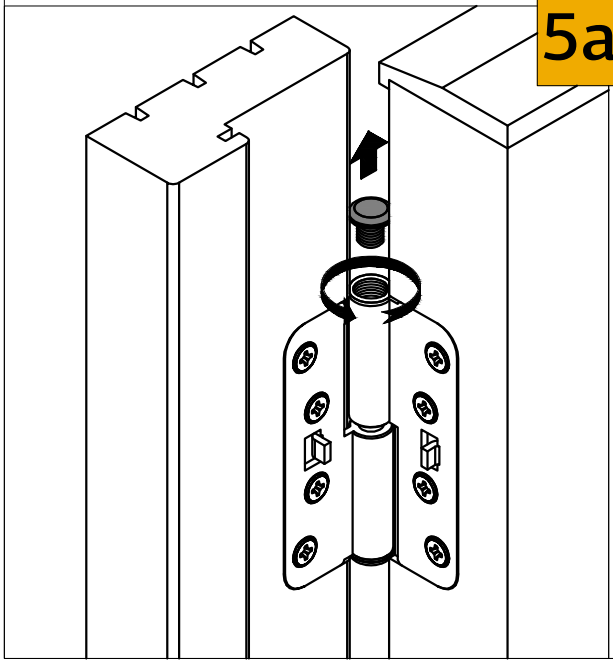

5b

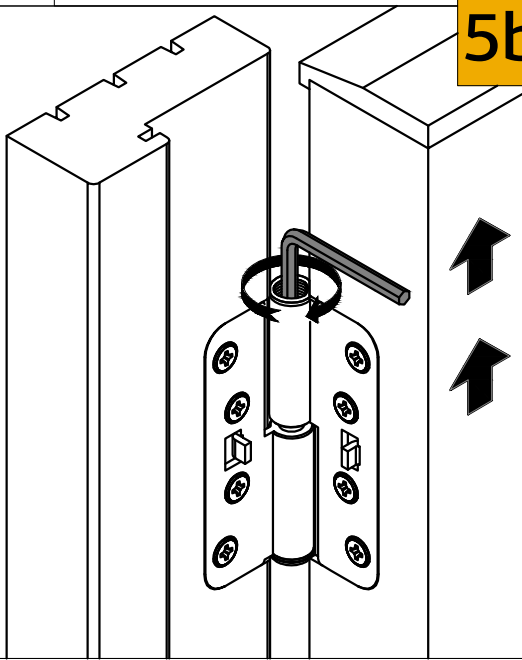

5c

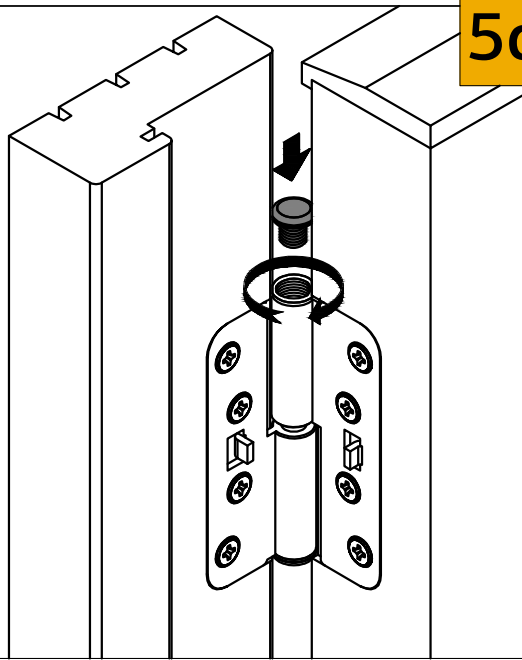

6

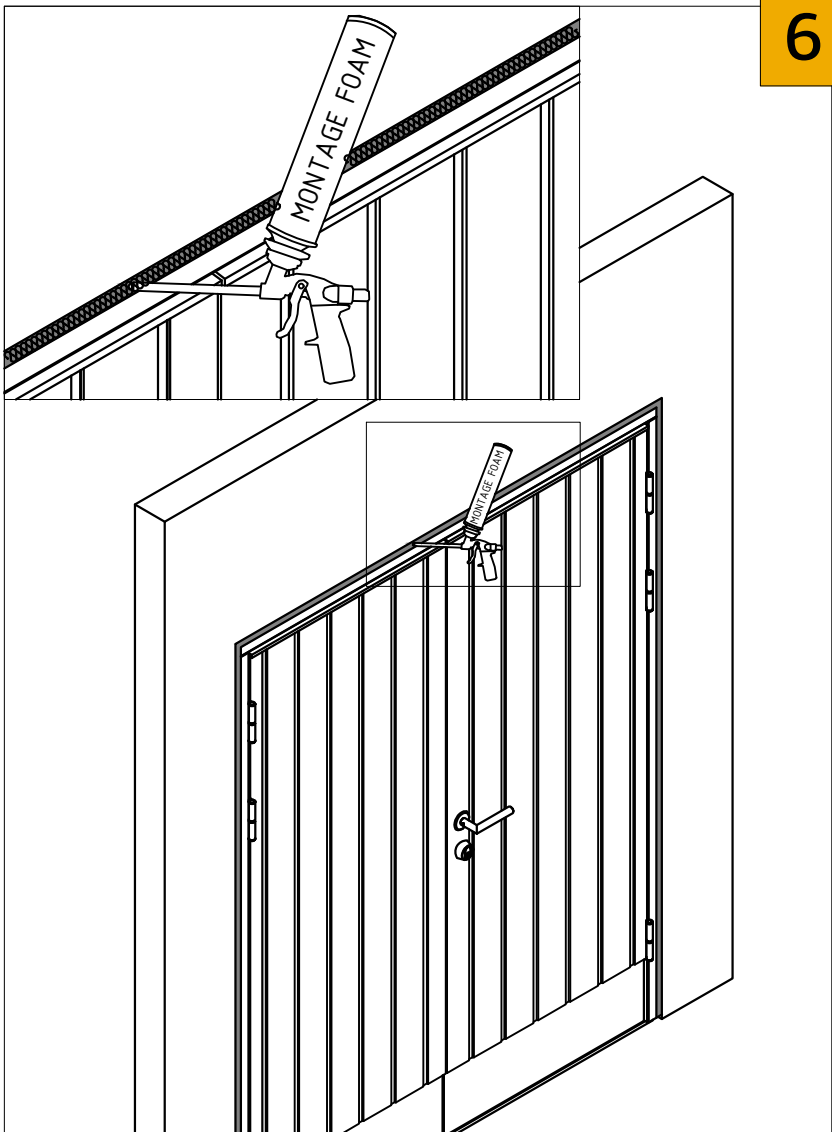

7

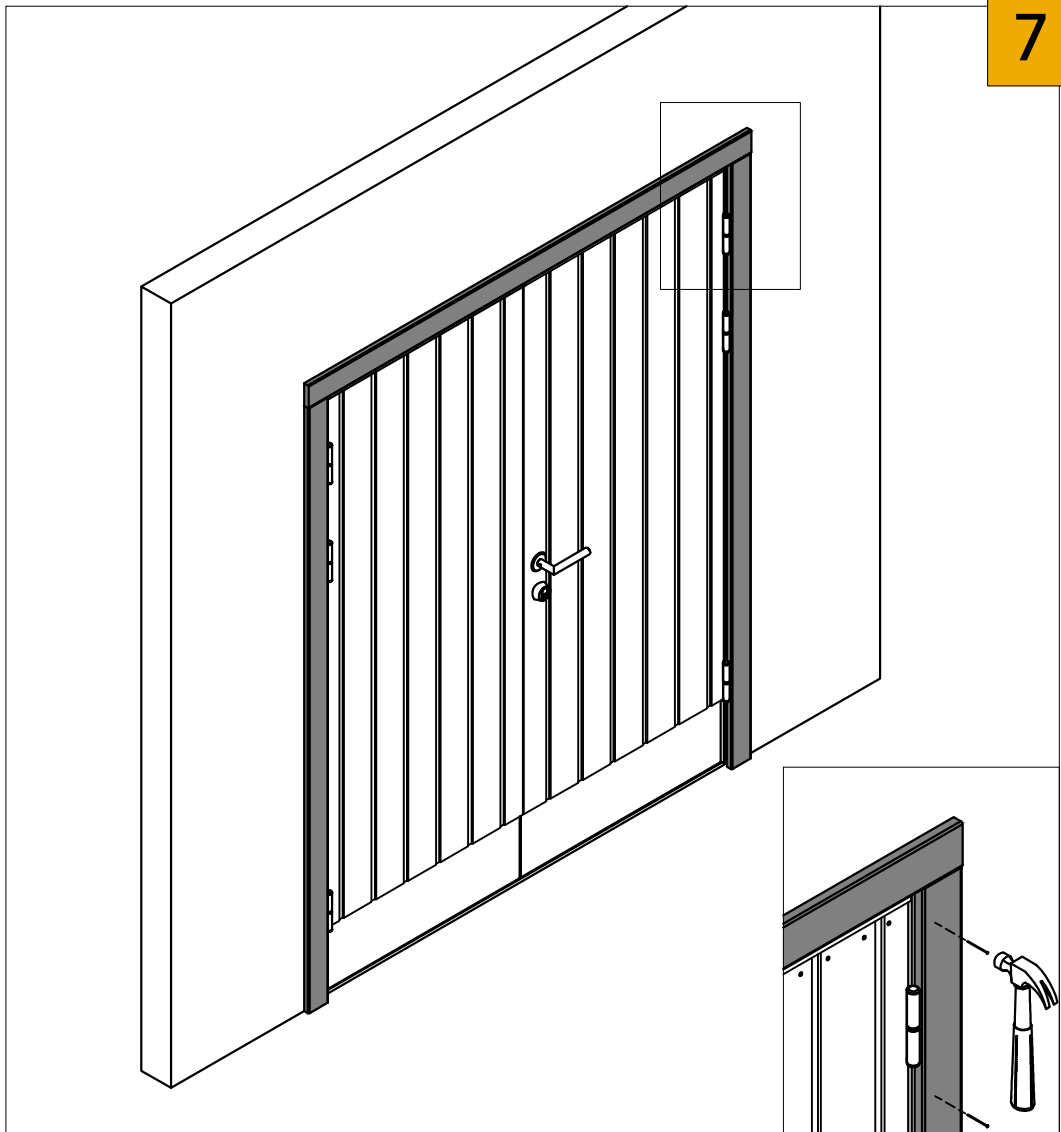

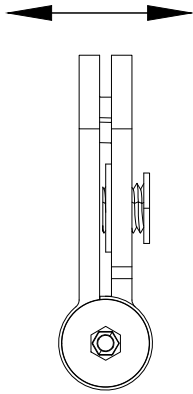
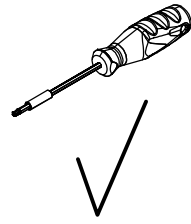
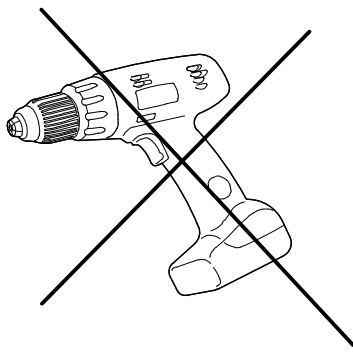

1.

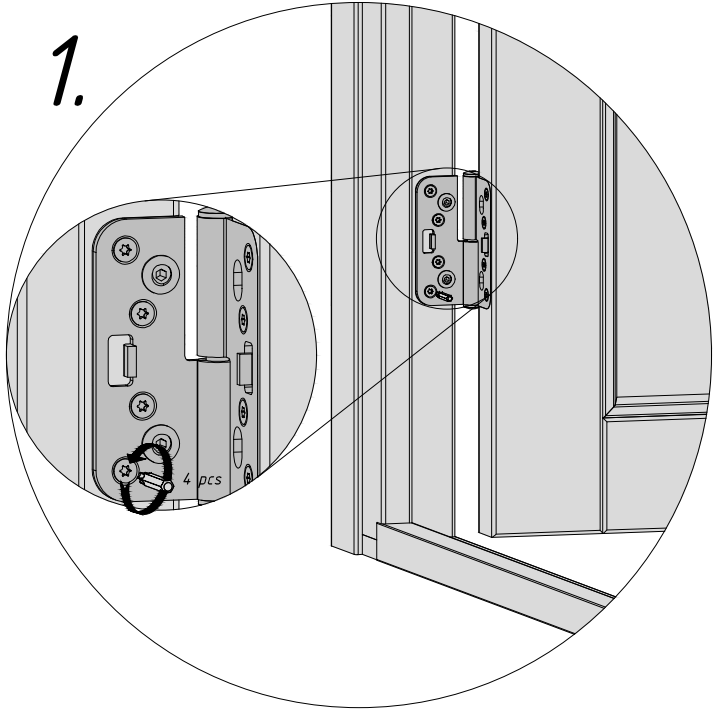

2.

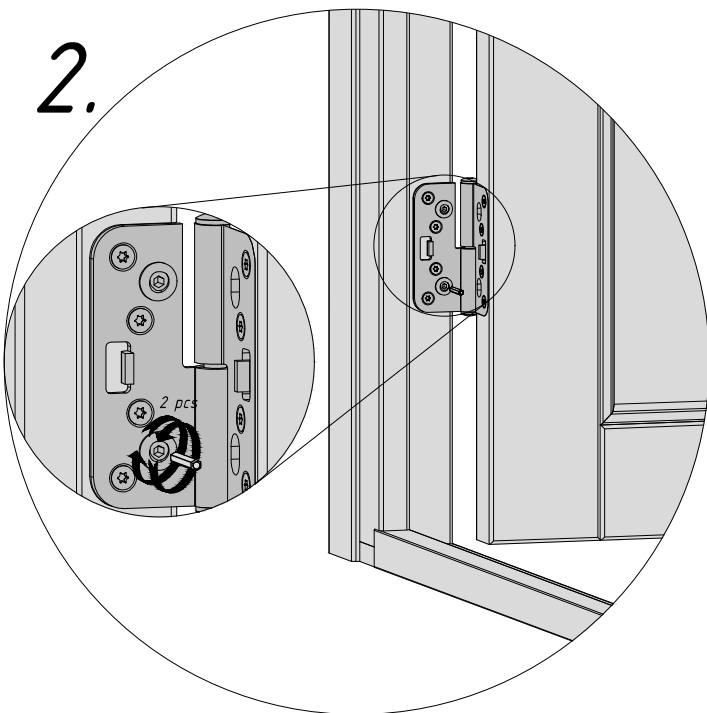

3.

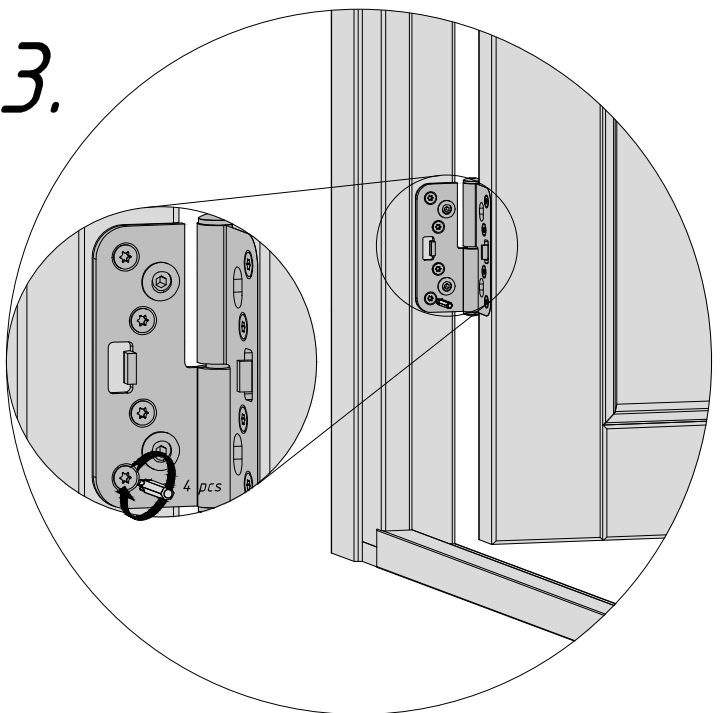

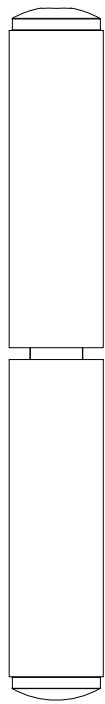
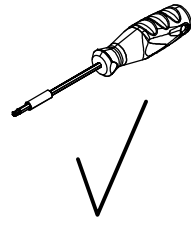
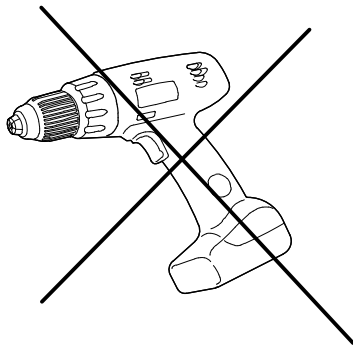

1.

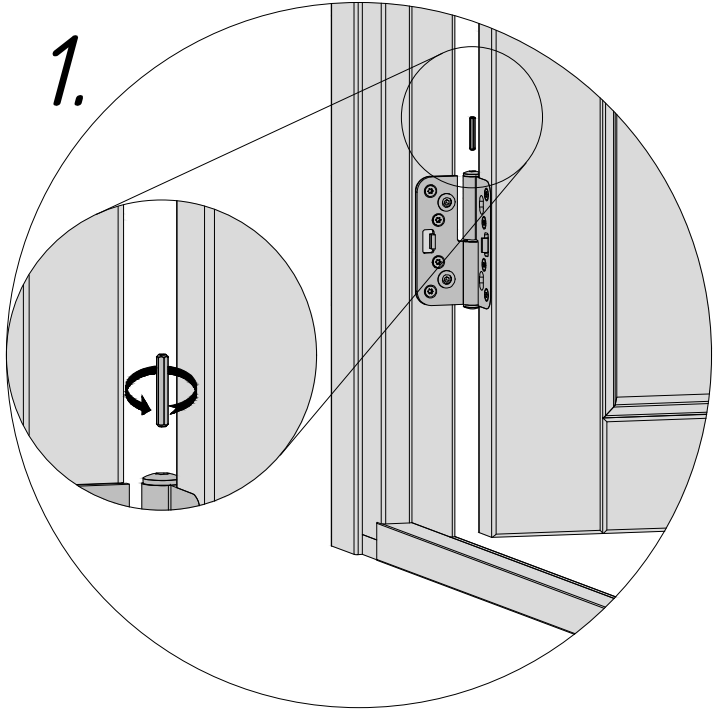

2.

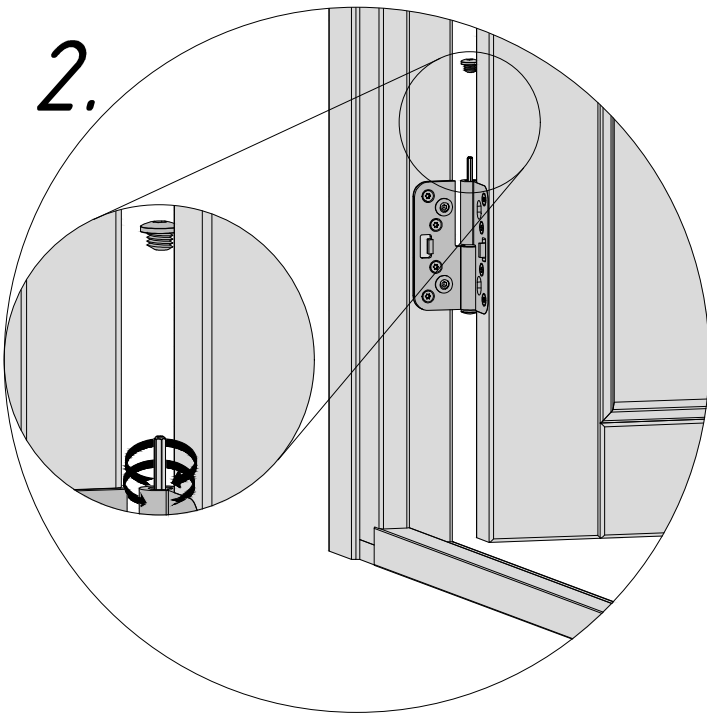

3.

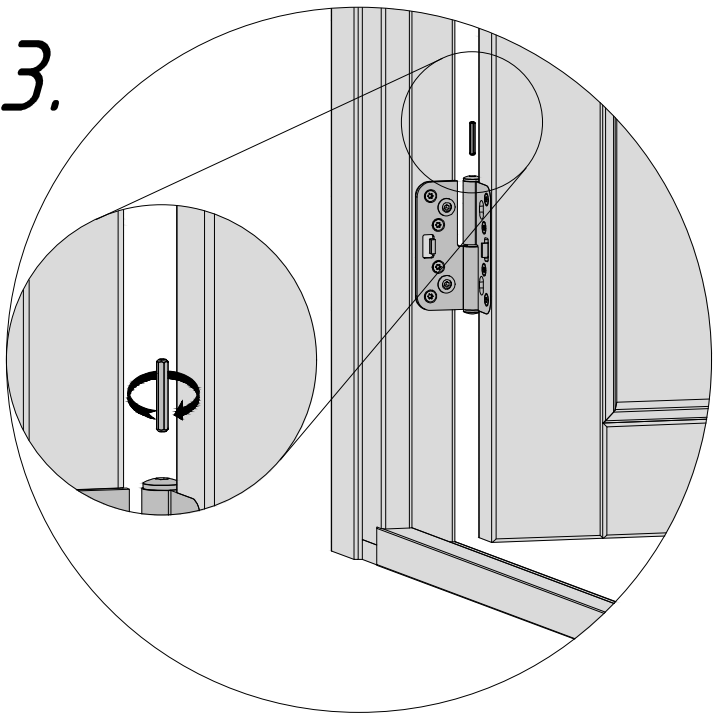

U90-20-919P

9x19

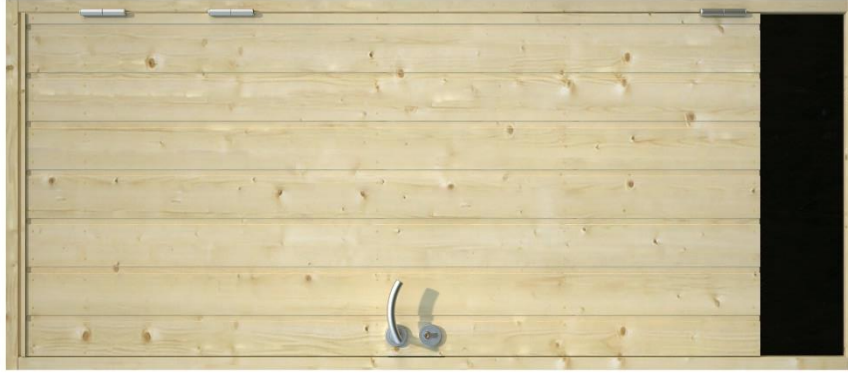

U90-20-919P
9x19

Palmako
LEMEKS GROUP

Palmako
LEMEKS GROUP

Näituse 25, 50409, Tartu, Estonia
Tel: +372 735 5530
Fax: +372 735 5544
www.palmako.ee

Note! Product that is used outdoors, needs to be painted before usage.

Notera! Produkt som används utomhus måste målas före användning.

Bemærk! Produkter, der anvendes udendørs, skal være malet før brug.

Merk! Produktet som skal brukes utendørs, må males før bruk.

Huomio! Ulkona käytettävät tuotteet täytyy värjätä ennen käyttöä.

Pane tähele! Kui toodet kasutatakse välitingimustes, tuleb seda enne kasutamist värvida.

Caps between window frame and door cladding needs to be filled with silicone before outdoors usage.

Håligheter mellan fönsterglaslist och träpanel behöver fyllas med fog innan utomhusanvändning.

Hulrum mellem vindue glas lister og paneler skal fyldes med fugemasse eller andet fyld før udendørs brug.

Hulrom mellom vindu glass listverk og trepanel må fylles med fugemasse eller annen fylling før utendørsbruk.

Välit ikkunankehysten ja oven laudoituksen välillä täytyy tasoittaa silikonilla ennen ulkokäyttöä.

Välitingimustes tuleb aknaraami ja ukse laudise vahel olevad vahed täita silikooniga.

TOOLS REQUIRED

VERKTYG SOM DU BEHÖVER

VERKTUJ, DU SKAL BRUGE

VERKTÜY SOM DU TRENGER

ASENNUKSESSA TARVITTAVAT TYÖKALUT

VAJALIKUD TÖÖRIISTAD

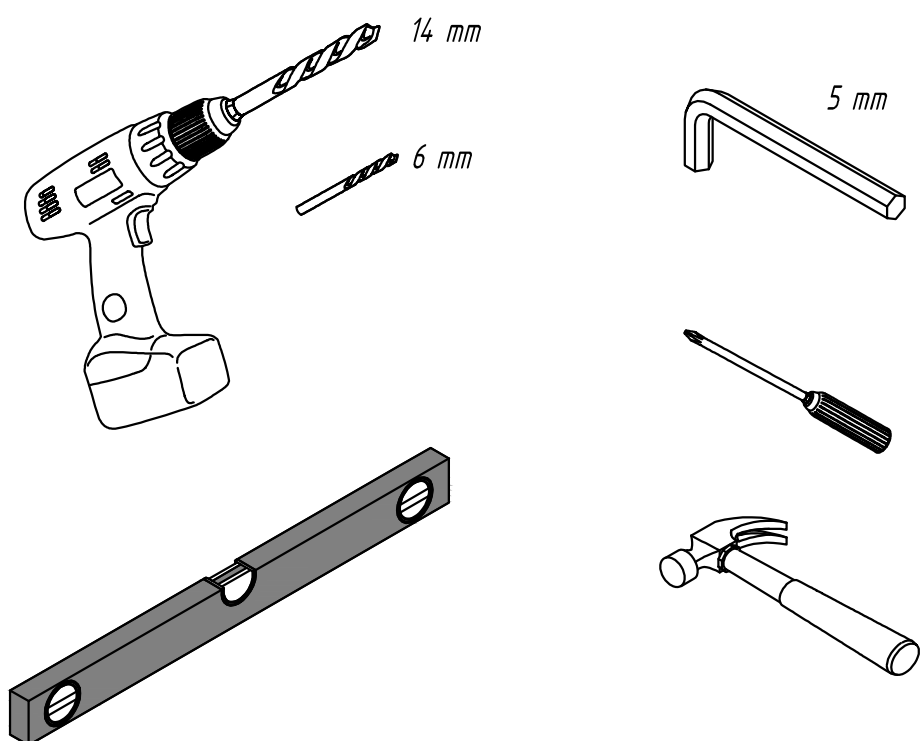

ACCESSORIES NOT INCLUDED

TILLBEHÖR SOM DU BEHÖVER

TILBEHØR, DER IKKE MEDFØLGER

TILBEHØR SOM IKKE FØLGER MED

ASENNUKSESSA TARVITTAVAT TARVIKKEET

PUUDUVAD LISAMATERJALID

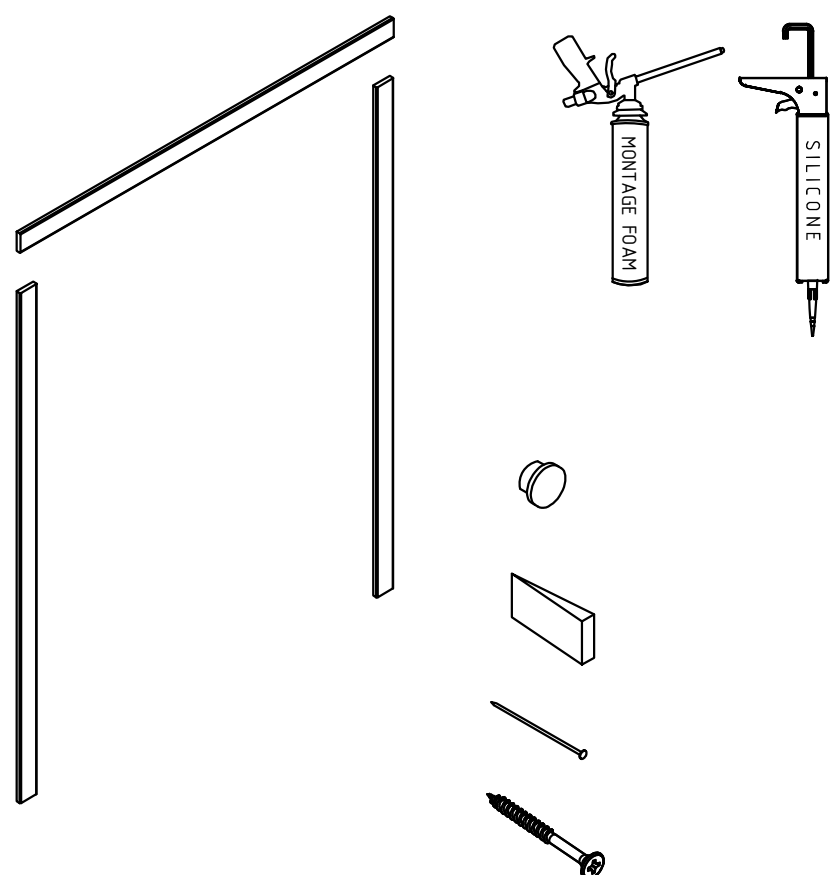

1

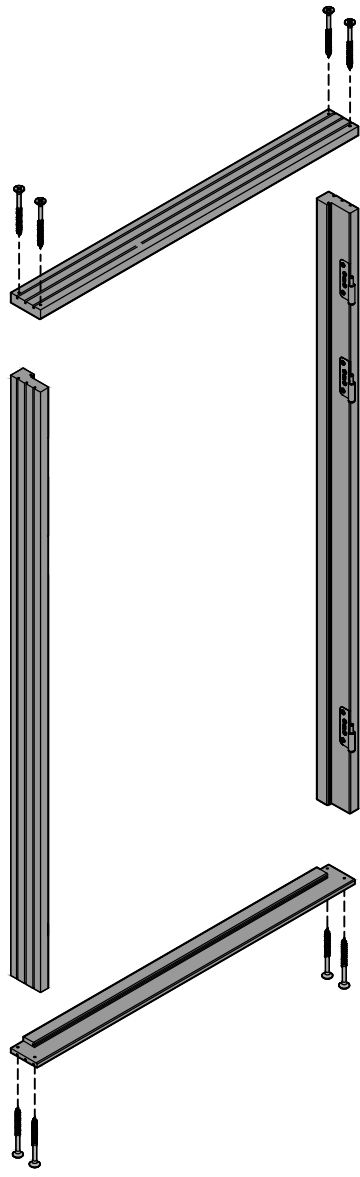

3

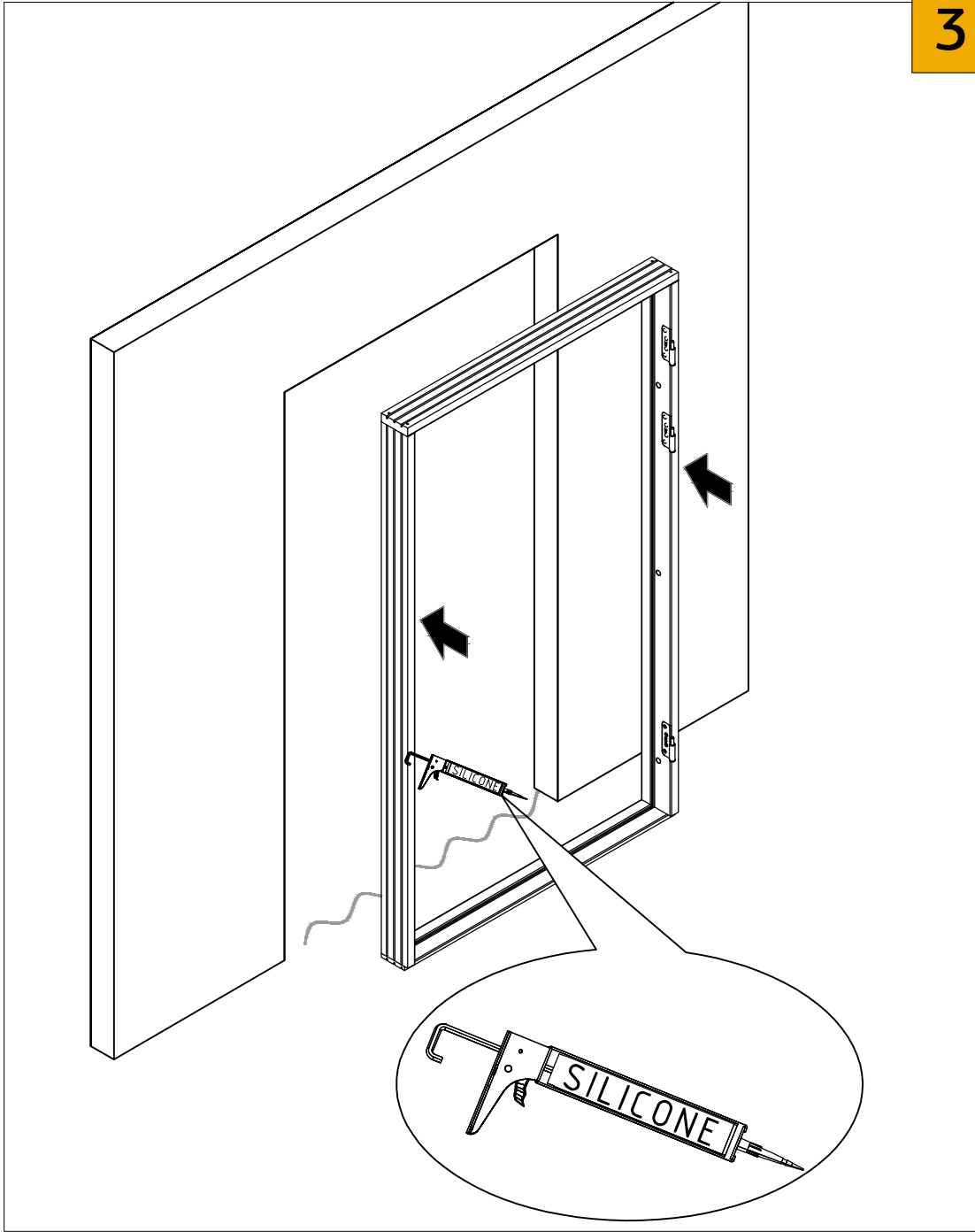

2

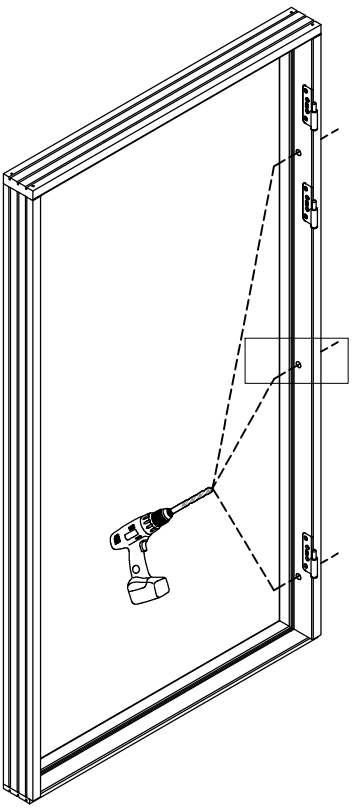

4

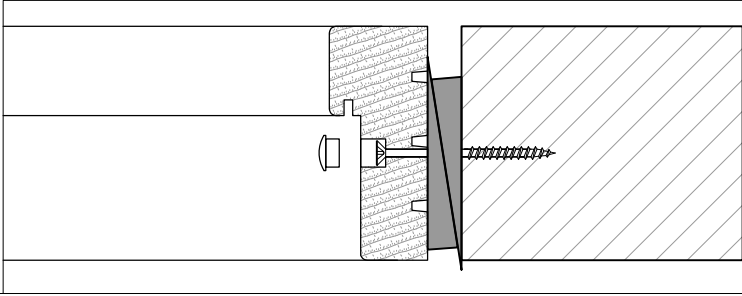
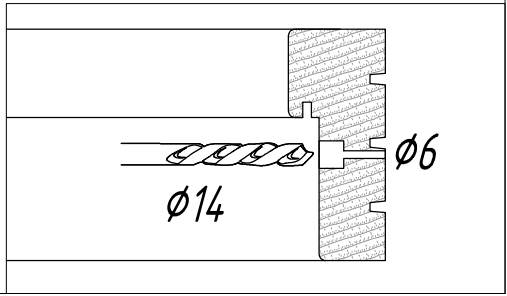
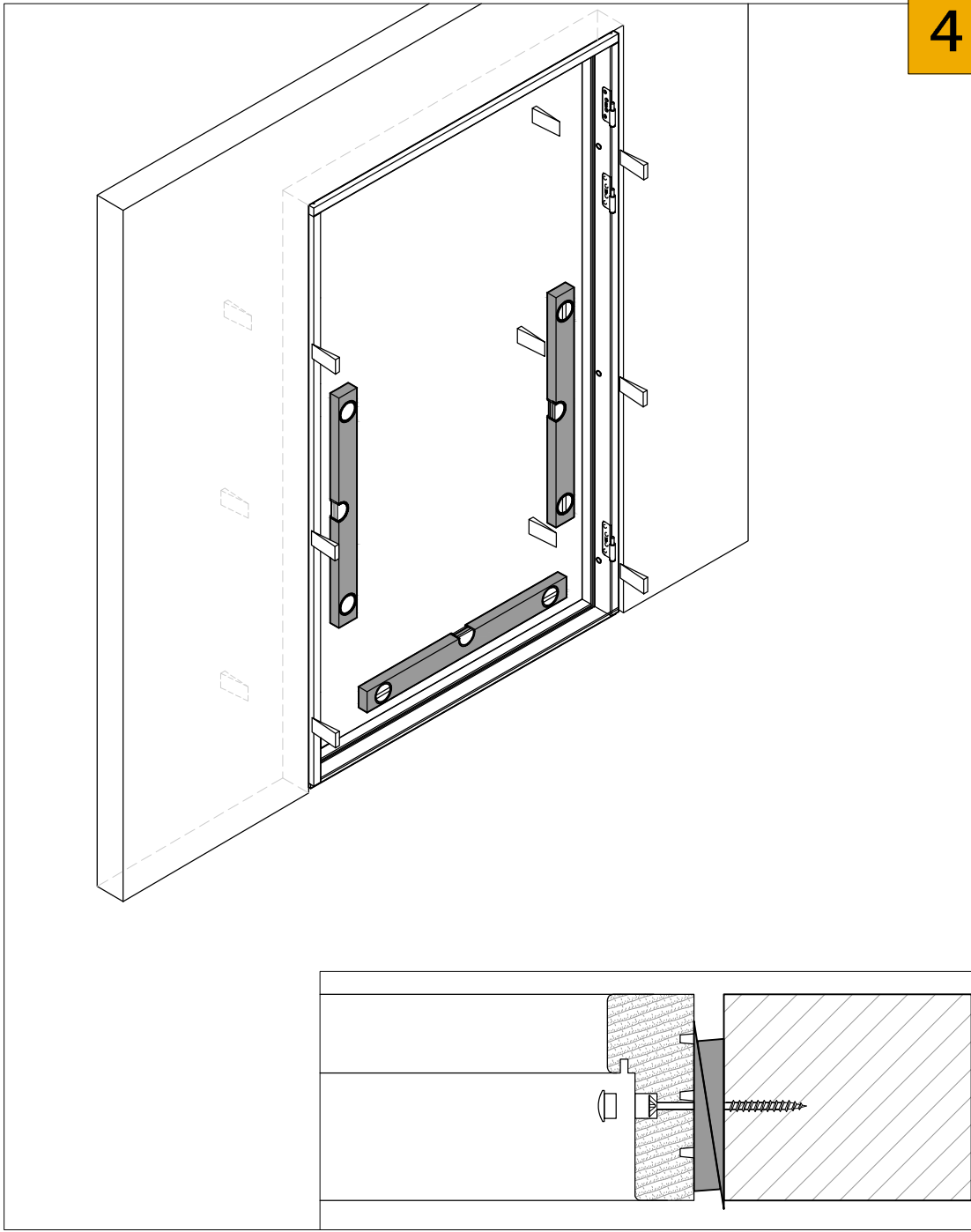

5

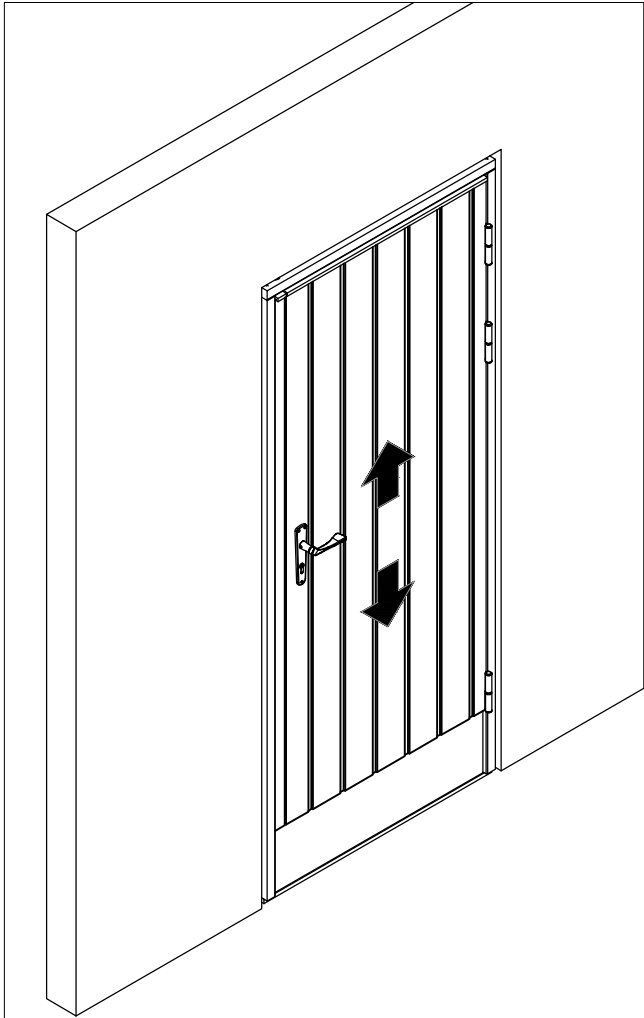

5a

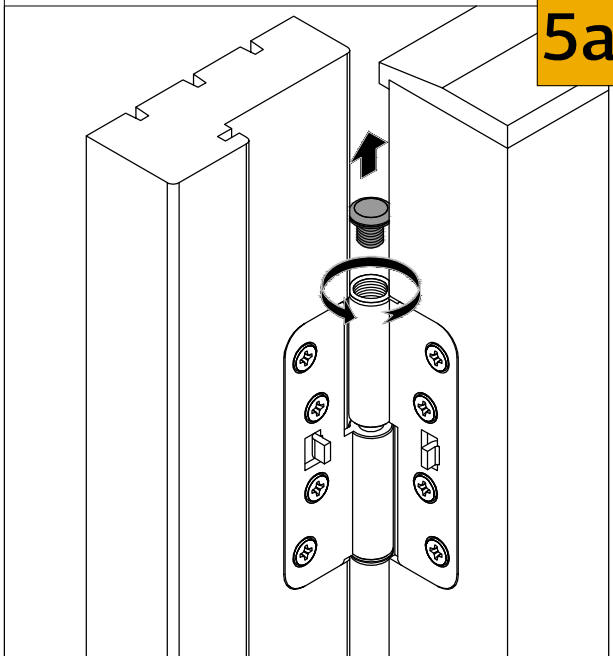

5b

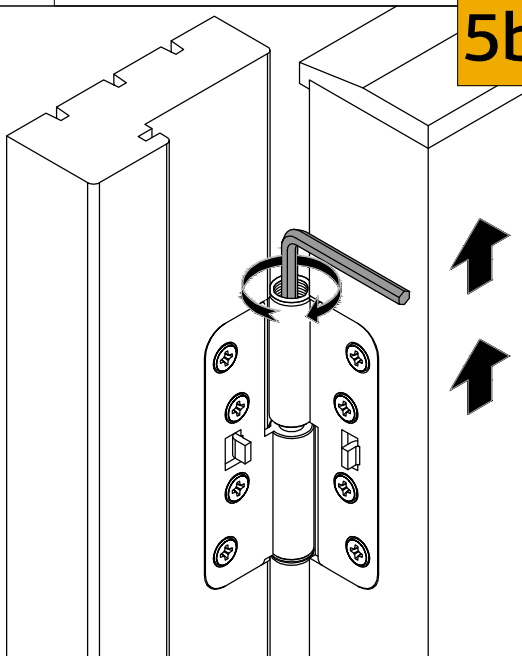

5c

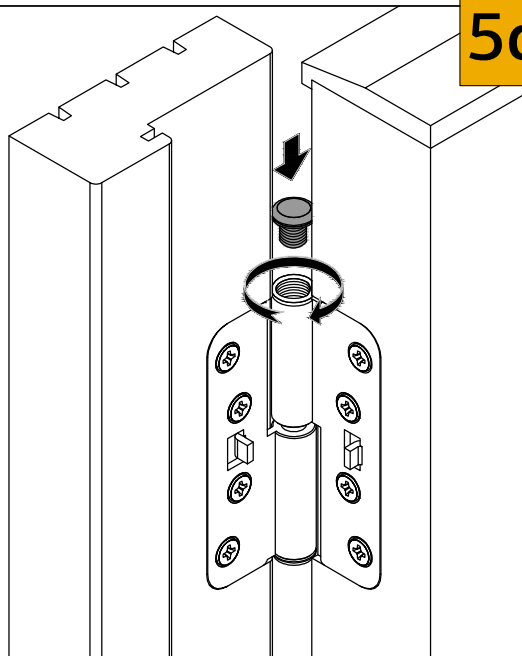

6

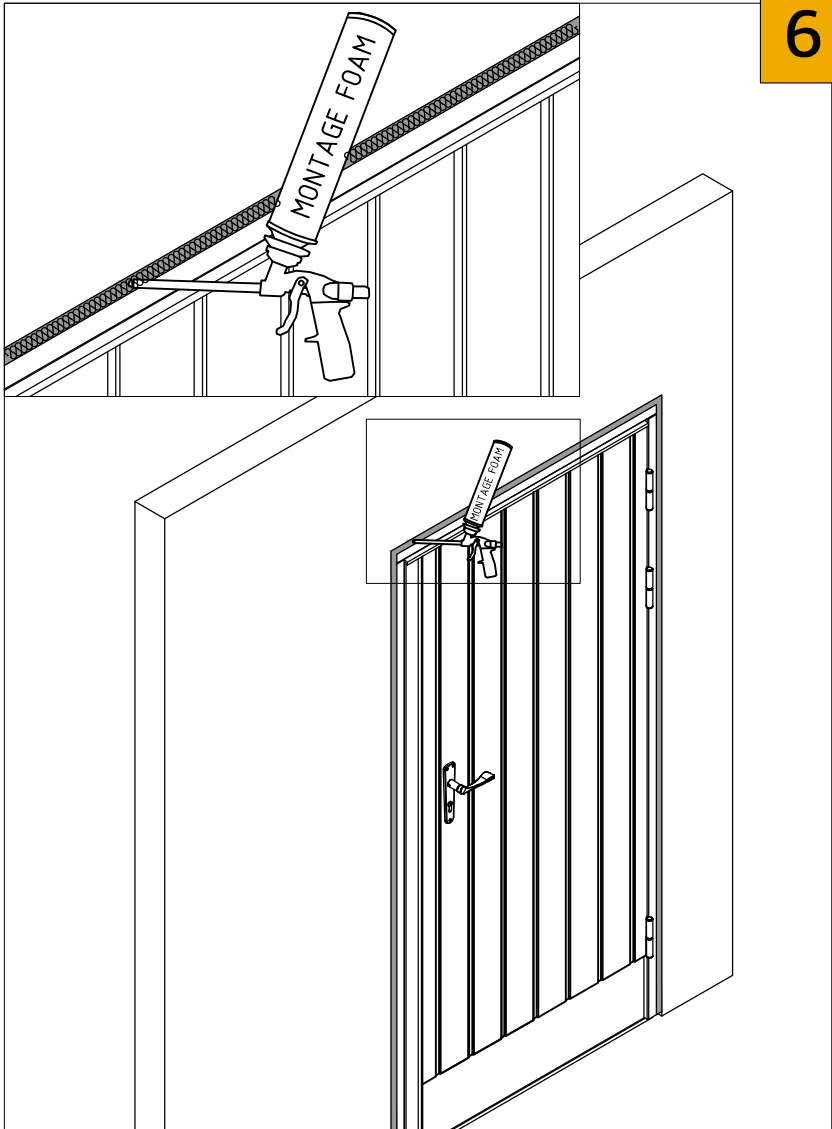

7

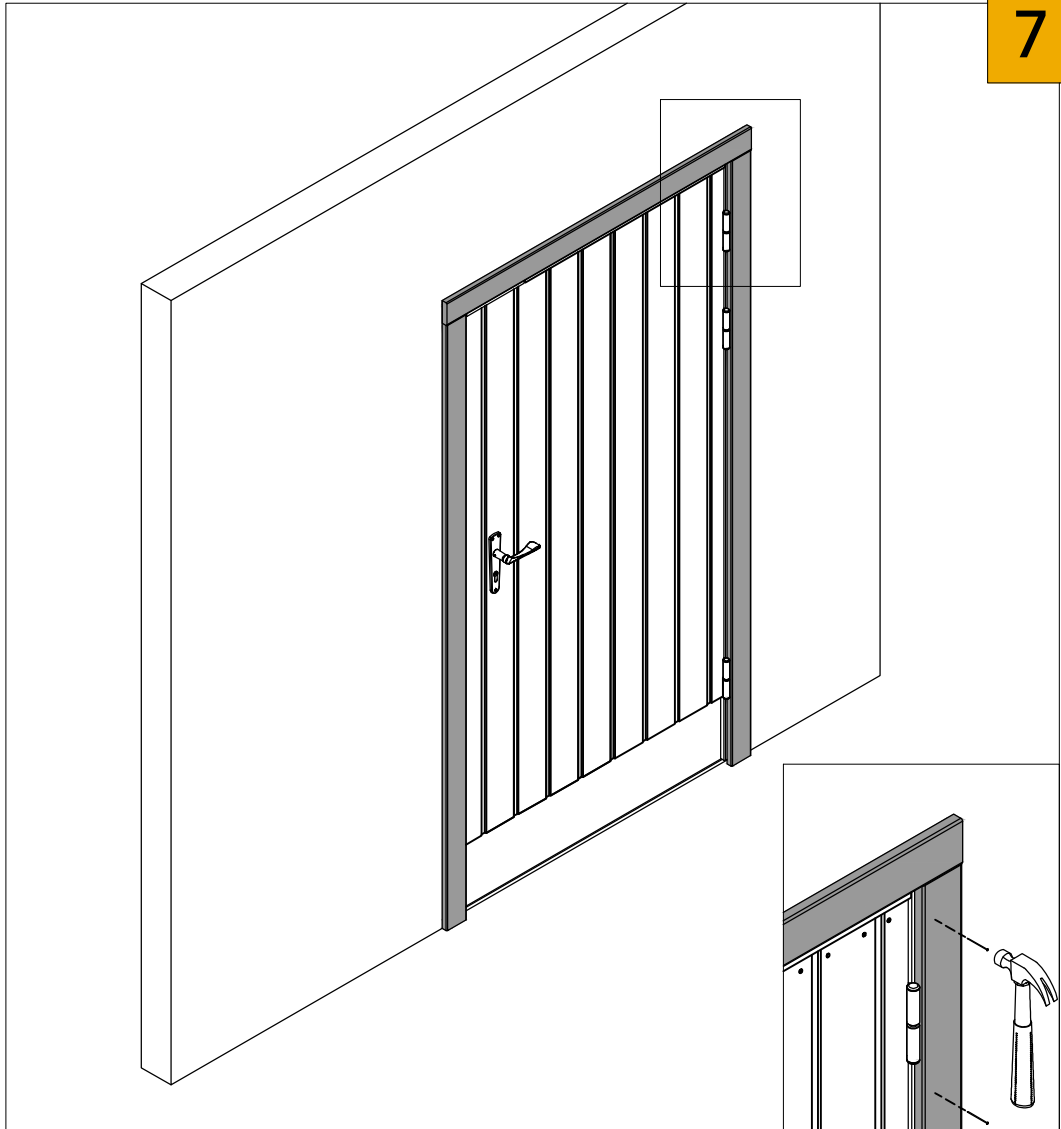

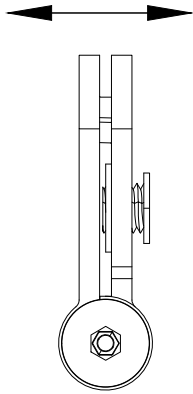
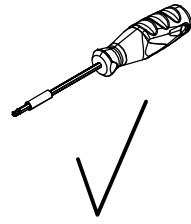
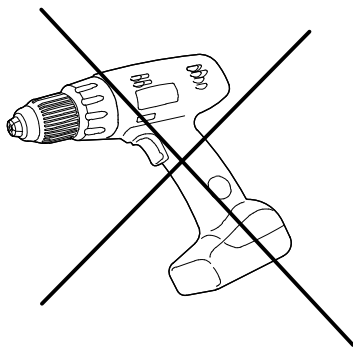

1.

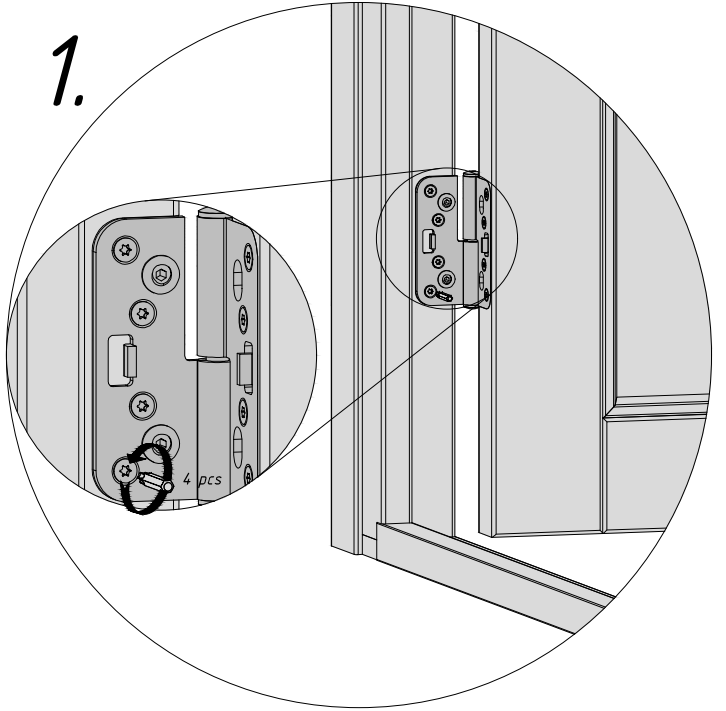

2.

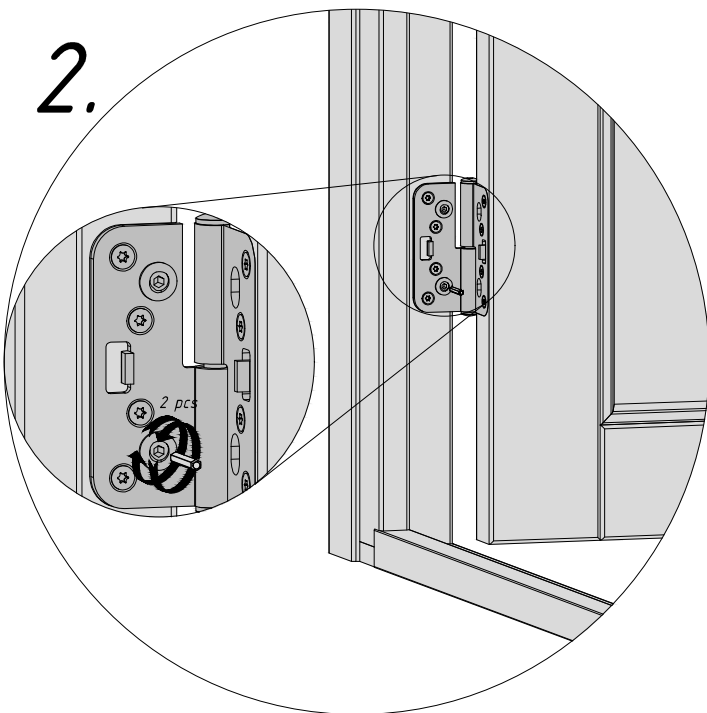

3.

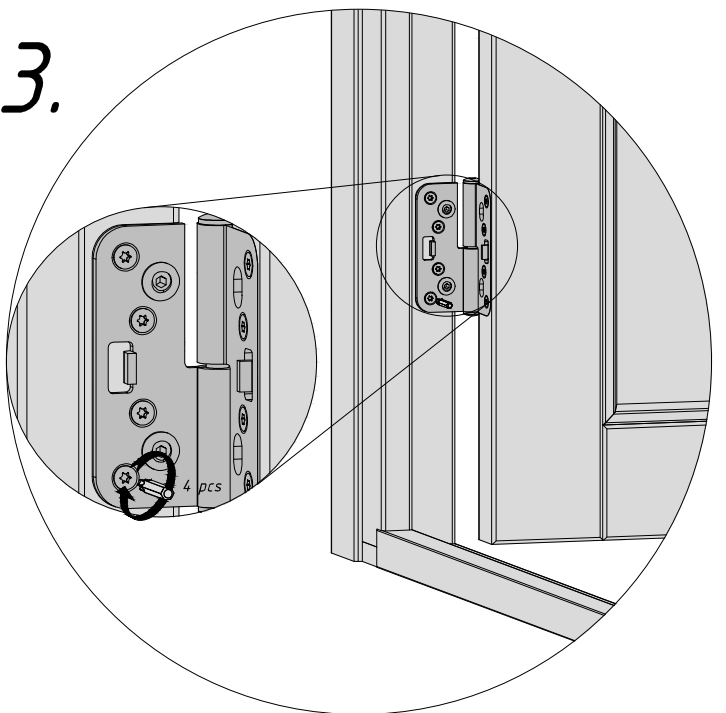

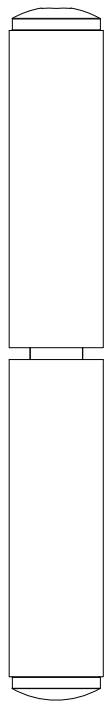
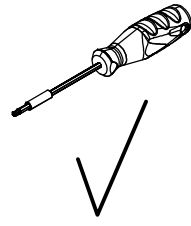
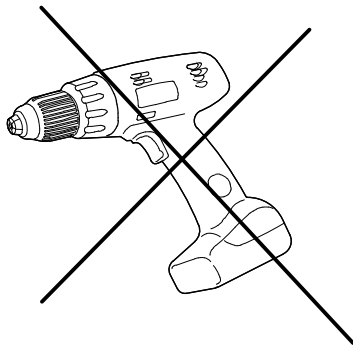

1.

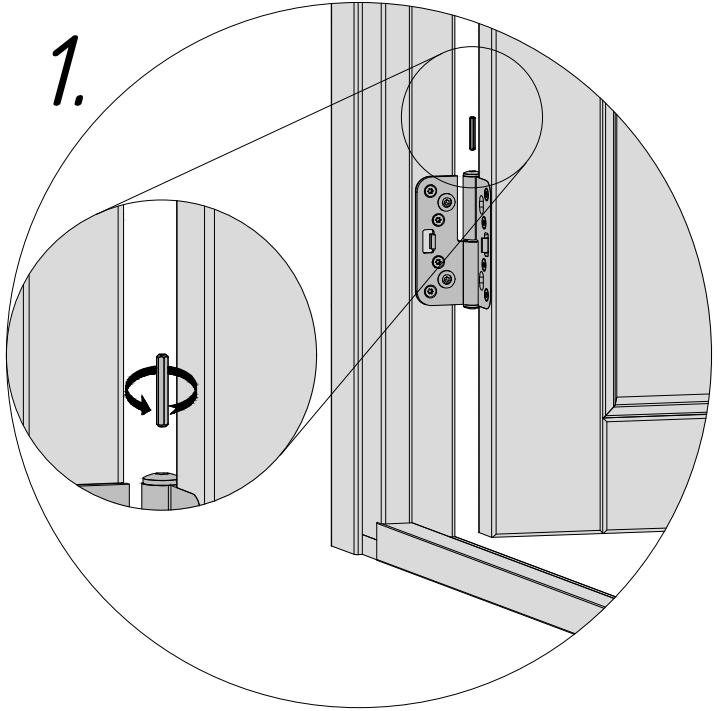

2.

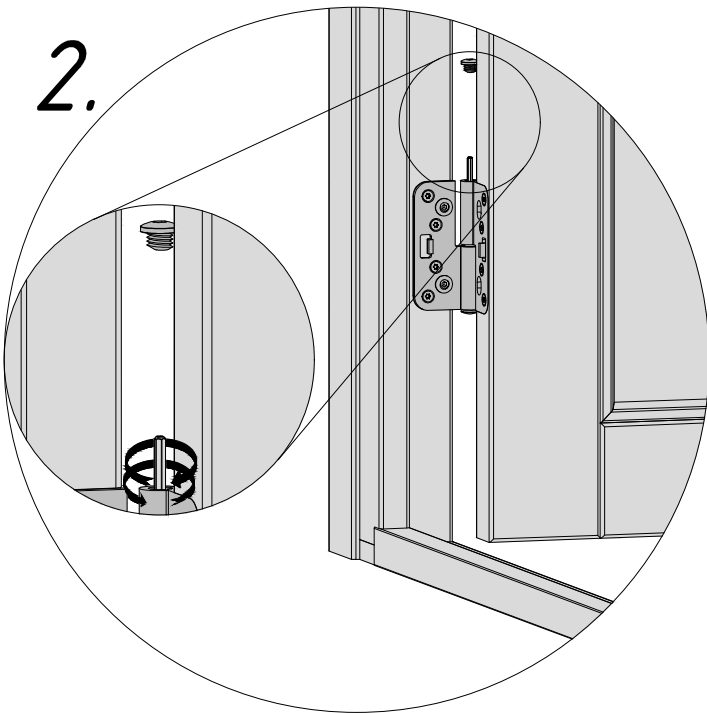

3.

